





Test Report issued under the responsibility of:



<b>TEST REPORT</b> <b>IEC 60884-1</b> <b>Plugs and socket-outlets for household and similar purposes</b> <b>Part 1: General requirements</b>	
<b>Report Number.....:</b>	<b>495103 / 10.19</b>
<b>Date of issue.....:</b>	<b>21.10.2019</b>
<b>Total number of pages .....</b>	<b>59</b>
<b>Name of Testing Laboratory preparing the Report.....:</b>	<b>TSE ANKARA ELECTROTECHNICAL LABORATORY</b> <b>Necatibey Caddesi, No:112, 06100, Bakanlıklar / ANKARA / TÜRKİYE</b>
<b>Applicant's name .....</b>	<b>MONO ELEKTRİK MALZEMELERİ SAN. VE DIŞ TİC.</b>
<b>Address .....</b>	<b>AKPINAR SANAYİ BÖLGESİ, YASSIÖREN KÖYÜ,</b> <b>HADIMKÖY CAD. NO: 162, ARNAVUTKÖY / İSTANBUL / TÜRKİYE</b>
<b>Test specification:</b>	
<b>Standard.....:</b>	<b>IEC 60884-1:2002, AMD1:2006, AMD2:2013</b>
<b>Test procedure .....</b>	<b>CB Scheme</b>
<b>Non-standard test method .....</b>	<b>N/A</b>
<b>Test Report Form No. ....:</b>	<b>IEC60884_1G</b>
<b>Test Report Form(s) Originator .....</b>	<b>IMQ S.p.A.</b>
<b>Master TRF.....:</b>	<b>Dated 2019-05-07</b>
<b>Copyright © 2019 IEC System of Conformity Assessment Schemes for Electrotechnical Equipment and Components (IECEE System). All rights reserved.</b>	
This publication may be reproduced in whole or in part for non-commercial purposes as long as the IECEE is acknowledged as copyright owner and source of the material. IECEE takes no responsibility for and will not assume liability for damages resulting from the reader's interpretation of the reproduced material due to its placement and context.	
If this Test Report Form is used by non-IECEE members, the IECEE/IEC logo and the reference to the CB Scheme procedure shall be removed.	
<b>This report is not valid as a CB Test Report unless signed by an approved CB Testing Laboratory and appended to a CB Test Certificate issued by an NCB in accordance with IECEE 02.</b>	
<b>General disclaimer:</b>	
The test results presented in this report relate only to the object tested.	
This report shall not be reproduced, except in full, without the written approval of the Issuing CB Testing Laboratory. The authenticity of this Test Report and its contents can be verified by contacting the NCB, responsible for this Test Report.	



<b>Test item description</b> .....	16A, 250V ~, IP 54, increased protection, screw-type, surface-type, without shutters, design A, with side earthing contact, 2P+E, single and double socket-outlets	
<b>Trade Mark</b> .....	MONO	
<b>Manufacturer</b> .....	MONO ELEKTRİK MALZEMELERİ SAN. VE DIŞ TIC. LTD. ŞTİ. (AKPINAR SANAYİ BÖLGESİ, YASSIÖREN KÖYÜ, HADIMKÖY CAD. NO: 162, ARNAVUTKÖY / İSTANBUL / TÜRKİYE)	
<b>Model/Type reference</b> .....	Table 1	
<b>Ratings</b> .....	16A, 250V ~	
<b>Responsible Testing Laboratory (as applicable), testing procedure and testing location(s):</b>		
<input checked="" type="checkbox"/>	<b>CB Testing Laboratory:</b>	TSE ANKARA ELECTROTECHNICAL LABORATORY
<b>Testing location/ address</b> .....		Necatibey Caddesi, No:112, 06100, Bakanlıklar / ANKARA / TÜRKİYE
<b>Tested by (name, function, signature)</b> .....		Bertan KAHRAMAN (Testing Expert) 
<b>Witnessed by (name, function, signature)</b> .....		Hülya ÖCAL (Technical Chief) 
<b>Approved by (name, function, signature)</b> .....		Ahmet Metin GEDİK (Laboratory Manager Dep.) 
<input type="checkbox"/>	<b>Testing procedure: CTF Stage 1:</b>	
<b>Testing location/ address</b> .....		
<b>Tested by (name, function, signature)</b> .....		
<b>Approved by (name, function, signature)</b> .....		
<input type="checkbox"/>	<b>Testing procedure: CTF Stage 2:</b>	
<b>Testing location/ address</b> .....		
<b>Tested by (name + signature)</b> .....		
<b>Witnessed by (name, function, signature)</b> .....		
<b>Approved by (name, function, signature)</b> .....		
<input type="checkbox"/>	<b>Testing procedure: CTF Stage 3:</b>	
<input type="checkbox"/>	<b>Testing procedure: CTF Stage 4:</b>	
<b>Testing location/ address</b> .....		
<b>Tested by (name, function, signature)</b> .....		
<b>Witnessed by (name, function, signature)</b> .....		
<b>Approved by (name, function, signature)</b> .....		
<b>Supervised by (name, function, signature)</b> .....		

TRF No. IEC60884\_1G



<b>List of Attachments (including a total number of pages in each attachment):</b>	
<b>Summary of testing:</b>	
<b>Tests performed (name of test and test clause):</b> <b>Clause</b> <b>8,9,10,11,12,13,16,17,18,19,20,21,22,24,25,26,27,28</b>	<b>Testing location:</b> <b>TSE ANKARA ELECTROTECHNICAL LABORATORY</b> <b>Necatibey Caddesi, No:112, 06100, Bakanlıklar / ANKARA / TÜRKİYE</b>
<b>Summary of compliance with National Differences (List of countries addressed):</b> TS 40 / PLUGS AND SOCKET OUTLETS FOR HOUSEHOLD AND SIMILAR PURPOSES--STANDARD SHEETS (TS 40 / Sheet 7 = CEE 7: Sheet III)	
<input type="checkbox"/> The product fulfils the requirements of _____ (insert standard number and edition and delete the text in parenthesis, leave it blank or delete the whole sentence, if not applicable)	

TRF No. IEC60884\_1G



**Copy of marking plate:**

**The artwork below may be only a draft. The use of certification marks on a product must be authorized by the respective NCBS that own these marks.**

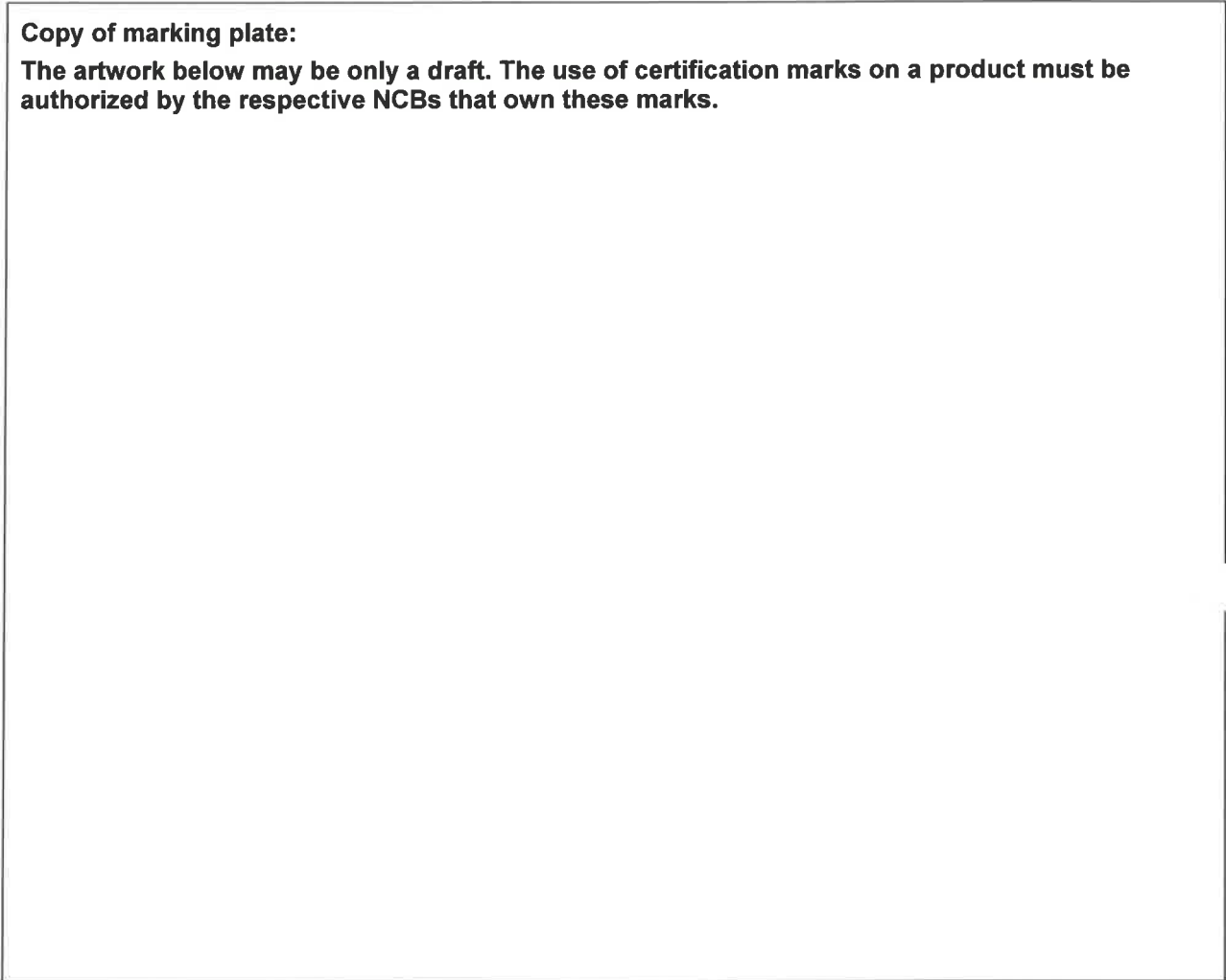

<b>Test item particulars</b> .....	
<b>Standard Sheet</b> .....	(TS 40 / Sheet 7 = CEE 7: Sheet III)
<b>Rated current (A) / Rated voltage (V)</b> .....	16 A / 250 V ~
<b>Degree of protection against access to hazardous parts and against harmful ingress of solid foreign objects</b> .....	IP2X / IP4X / IP5X
<b>Degree of protection against harmful ingress of water</b> .....	IPX0 / IPX4 / IPX5 / IPX6
<b>Provision for earthing</b> .....	without earthing contact / with earthing contact
<b>Method of connecting the cable</b> .....	rewirable / non-rewirable
<b>Type of cable</b> .....	
<b>Nominal cross-sectional areas (mm<sup>2</sup>)</b> .....	1,5mm <sup>2</sup> - 2 x 2,5mm <sup>2</sup>
<b>Type of terminals</b> .....	screw-type / screwless (rigid) / screwless (rigid and flexible)
<b>Type of connections</b> .....	soldered / welded / crimped / other
<b>Socket-outlets:</b>	
<b>Degree of protection against electric shock</b> :	normal protection / increased protection
<b>Existence of shutters</b> .....	without shutters / with shutters
<b>Method of application / mounting of the socket-outlet</b> .....	surface-type / flush-type / semi-flush-type / panel type / architrave-type / portable-type / table-type (single/multiple) / floor-recessed type / appliance type
<b>Method of installation</b> .....	design A / design B
<b>Intended for circuits where</b> .....	a single earthing circuit provides protective earthing / electrical noise immunity is desired for the earthing circuit
<b>Plugs:</b>	
<b>Class of equipment</b> .....	0 / I / II
<b>Possible test case verdicts:</b>	
- test case does not apply to the test object .....	N/A
- test object does meet the requirement .....	P (Pass)
- test object does not meet the requirement .....	F (Fail)
<b>Testing</b> .....	
<b>Date of receipt of test item</b> .....	12.04.2019
<b>Date (s) of performance of tests</b> .....	24.05.2019 – 31.07.2019
<b>General remarks:</b>	
"(See Enclosure #)" refers to additional information appended to the report. "(See appended table)" refers to a table appended to the report.	
Throughout this report a <input checked="" type="checkbox"/> comma / <input type="checkbox"/> point is used as the decimal separator.	



<b>Manufacturer's Declaration per sub-clause 4.2.5 of IEC60068-2-1:</b>	
The application for obtaining a CB Test Certificate includes more than one factory location and a declaration from the Manufacturer stating that the sample(s) submitted for evaluation is (are) representative of the products from each factory has been provided.....:	<input type="checkbox"/> <b>Yes</b> <input type="checkbox"/> <b>Not applicable</b>
<b>When differences exist; they shall be identified in the General product information section.</b>	
<b>Name and address of factory (ies) .....</b>	MONO ELEKTRİK MALZEMELERİ SAN. VE TIC. LTD. ŞTİ. AKPINAR SANAYİ BÖLGESİ, YASSIÖREN KÖYÜ, HADIMKÖY CAD. NO: 162, ARNAVUTKÖY / İSTANBUL / TÜRKİYE
<b>General product information and other remarks:</b>	
<b>This report is prepared according to 31/07/2019 dated and 481880 / 07.19 numbered Turkish report.</b>	



TABLE 1

TRADE MARK	MAIN BODY TYPE REFERENCE	PRODUCT TYPE REFERENCE	SPECIFICATIONS
MONO	07-117	154 XXXX 07 117	16A, 250V ~, IP 54, increased protection, screw-type, surface-type, without shutters, design A, with side earthing contact, 2P+E, single, socket-outlet
		154 XXXX 07 120	16A, 250V ~, IP 54, increased protection, screw-type, surface-type, without shutters, design A, with side earthing contact, 2P+E, double, socket-outlet

Serial Name / Code: OCTANS IP54 / 154 XXXX

TRF No. IEC60884\_1G





**PICTURES**

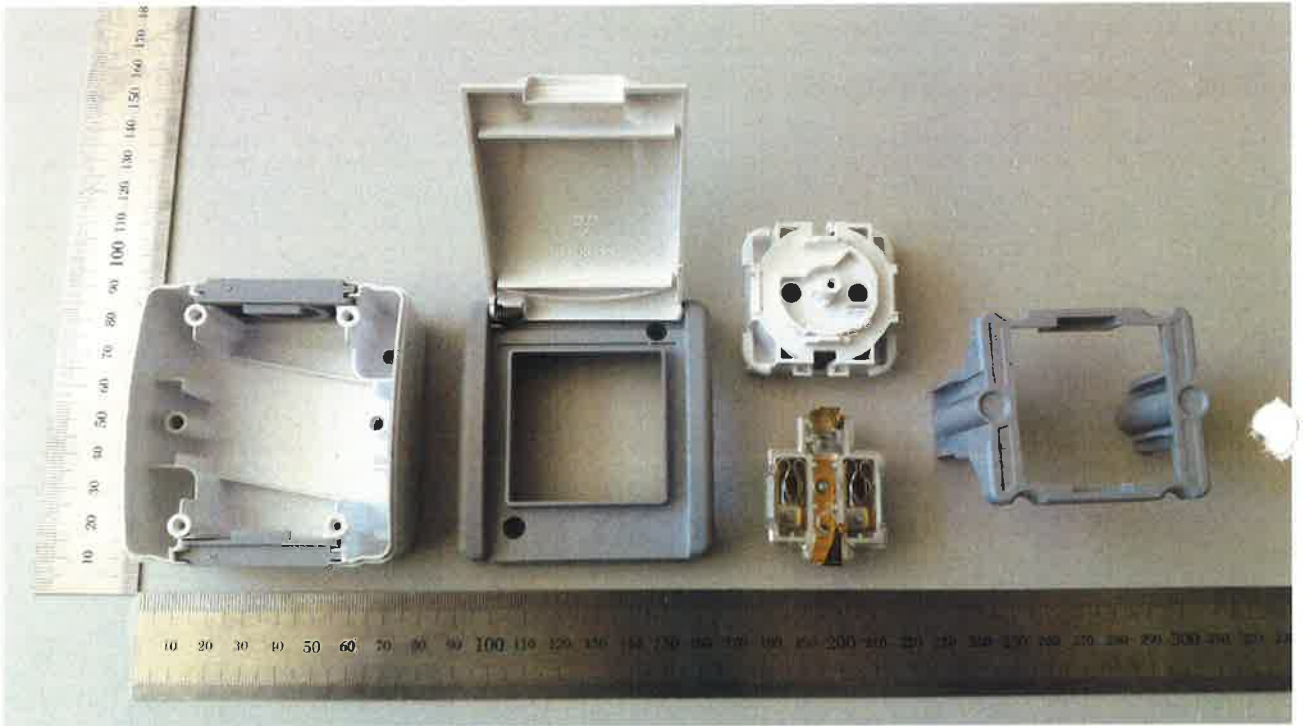
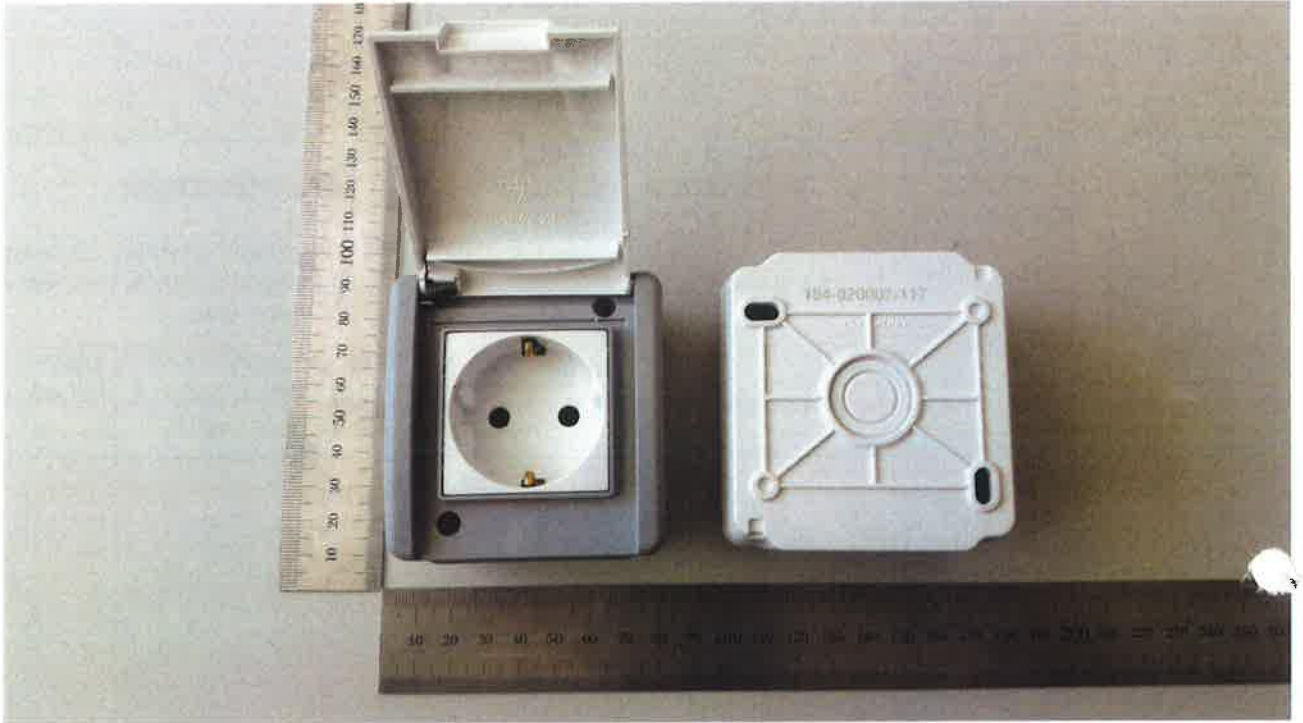

**154 XXXX 07 117**

TRF No. IEC60884\_1G





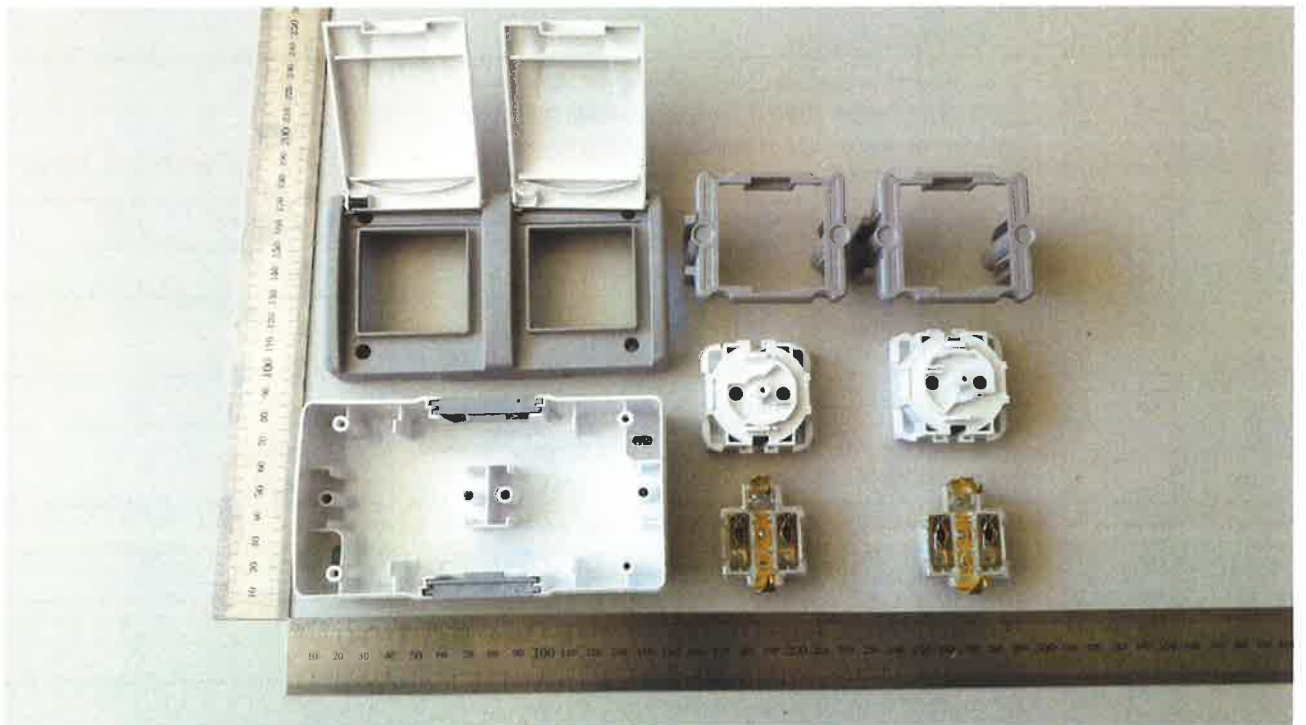
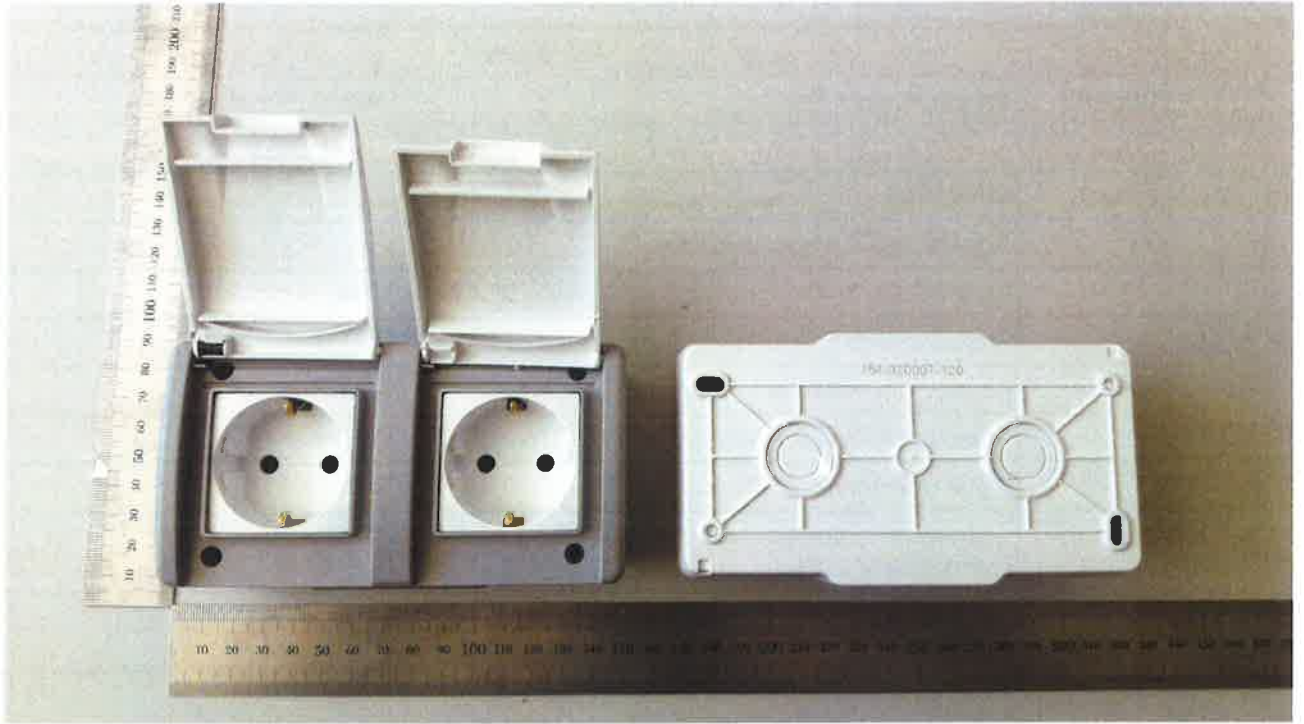

154 XXXX 07 120

TRF No. IEC60884\_1G



IEC 60884-1			
Clause	Requirement + Test	Result - Remark	Verdict
<b>8</b>	<b>MARKING</b>		
8.1	Accessories marked as follows:		
	- rated current (A) .....	16A	P
	- rated voltage (V) .....	250 V	P
	- symbol for nature of supply .....	~	P
	- manufacturer's or responsible vendor's name .....	MONO	P
	- type reference .....	Table 1	P
	- degree of protection (first characteristic numeral) if higher than 2.....	IP5X	P
	- degree of protection (second characteristic numeral) if higher than 0 .....	IPX4	P
	- degree of protection (first characteristic numeral) higher than 4 for fixed socket outlet in which case the second characteristic numeral shall also be marked .....	IP54	P
	- degree of protection (second characteristic numeral) higher than 2 for fixed socket outlet in which case the first characteristic numeral shall also be marked.....	IP54	P
	Socket-outlets with screwless terminals marked with the following:		
	- the length of insulation to be removed .....		N/A
	- an indication of the suitability to accept rigid conductors only (if any) .....		N/A
8.2	Symbols used: as required in the standard		P
	Marking for the nature of supply placed next to the marking for rated current and rated voltage		P
8.3	Marking of fixed socket-outlets placed on the main part:		
	- rated current, rated voltage and nature of supply		N/A
	- identification mark of the manufacturer or of the responsible vendor		N/A
	- length of insulation to be removed, if any		N/A
	- indication of the suitability to accept rigid conductors only for screwless terminals for those socket-outlets having this restriction	r	N/A
	- type reference		N/A
	Cover plates necessary for safety purposes and intended to be sold separately: marked with the manufacturer's or responsible vendor's name and type reference		N/A

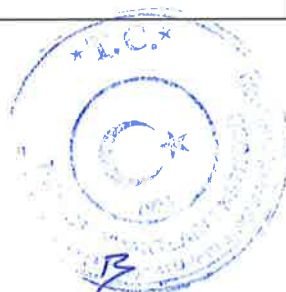

IEC 60884-1			
Clause	Requirement + Test	Result - Remark	Verdict
	IP code, if applicable: marked so as to be easily discernible		N/A
	Fixed socket-outlets classified according to item b) of 7.2.5: identified by a triangle visible after installation unless they have an interface configuration different from that used in normal circuits .....		N/A
8.4	Plugs and portable socket-outlets: marking specified in 8.1, other than the type reference, easily discernible		P
	Plugs and portable socket-outlets for equipment of class II not marked with the symbol for class II construction		N/A
8.5	Neutral terminals: N .....		N/A
	Earthing terminals: [earth symbol] .....		P
	Markings not placed on screws or other easily removable parts		P
	Terminals for conductors not forming part of the main function of the socket-outlet:		
	- clearly identified unless their purpose is self-evident, or		N/A
	- indicated in a wiring diagram fixed to the accessory		N/A
	Identification of such terminals may be achieved by:		
	- their being marked with graphical symbols according to IEC 60417-2 or colours and/or alphanumeric system, or		N/A
	- their being marked with their physical dimensions or relative location		N/A
8.6	Surface-type mounting boxes forming an integral part of socket-outlets having an IP code higher than IP4X, or higher than IPX2, the IP code marked on the outside of its associated enclosure so as to be easily discernible		P
8.7	Indication of which position or with which special provision the declared IP of flush-type and semi-flush-type fixed socket-outlets having IP>X0 is ensured		N/A
8.8	Marking durable and clearly legible with normal or corrected vision, without additional magnification. Test: 15 s with water and 15 s with petroleum spirit		P
<b>9</b>	<b>CHECKING OF DIMENSIONS</b>		
9.1	Accessories and surface-type mounting boxes comply with the appropriate standard sheets and corresponding gauges, if any	See Table 2	P

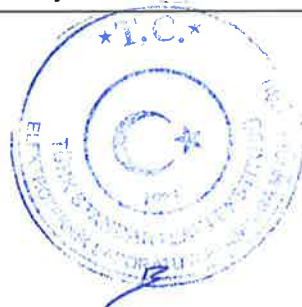

IEC 60884-1			
Clause	Requirement + Test	Result - Remark	Verdict
	Insertion of plugs into fixed or portable socket-outlets ensured by their compliance with the relevant standard sheets		P
	Compliance checked by measurement and by means of gauges with manufacturing tolerances as shown in table 2	See Table 2	P
9.2	It is not possible to engage a plug with:		
	- a socket-outlet having a higher voltage rating or a lower current rating;		P
	- a socket-outlet with a different number of live poles (exception admitted provided that no dangerous situation can arise);		P
	- a socket-outlet with earthing contact, if the existing plug of the present national system is a plug for class 0 equipment;		P
	Engagement of an existing plugs on the present national system for equipment of class 0 or of class I with a socket-outlet exclusively designed to accept plugs for class II equipment		P
	Impossibility of insertion checked by applying a gauge, for 1 min, with a force of:		
	- 150 N (rated current $\leq$ 16A);		N/A
	- 250 N (rated current $>$ 16A)		N/A
	Accessories with elastomeric or thermoplastic material: test carried out at $(35 \pm 2)$ °C		N/A
9.3	Deviations from standard sheets made only if they provide technical advantage and do not affect the purpose and safety of accessories complying with standard sheet		N/A
<b>10</b>	<b>PROTECTION AGAINST ELECTRIC SHOCK</b>		
10.1	Live parts not accessible, even after removal of parts which can be removed without the use of a tool for:		P
	Fixed socket-outlets		P
	Plugs when the plug is in partial or complete engagement with a socket-outlet		P
	Test with test probe B of IEC 61032		P
	Accessories with elastomeric or thermoplastic material: additional test carried out at $(35 \pm 2)$ °C with test probe 11 of IEC 61032 (75 N for 1 min)		P
	During the test: accessories not deform and no live parts accessible		P





IEC 60884-1			
Clause	Requirement + Test	Result - Remark	Verdict
	Plugs and portable socket-outlets pressed with a force of 150 N for 5 min as shown in figure 8: specimens not show deformation		N/A
10.2	Accessible parts (with exception of small screws and the like for fixing main parts and covers or cover plates): made of insulating material		P
	Cover or cover plates of fixed socket-outlets and accessible parts of portable socket-outlets: made of metal if the requirements of 10.2.1 or 10.2.2 are fulfilled		N/A
10.2.1	Accessible metal parts or accessible metal parts protected by supplementary insulation made by insulating linings or insulating barriers		N/A
	Insulating linings or insulating barriers cannot be removed without being permanently damaged		N/A
	Insulating linings or insulating barriers cannot be replaced in an incorrect position and, if they are omitted, accessories are rendered inoperable or manifestly incomplete		N/A
	There is no risk of accidental contact between live parts and metal covers or cover plates		N/A
10.2.2	Accessible metal parts are reliably connected, through a low-resistance connection, to the earth during fixing		N/A
10.3	Contact between a pin of a plug and a live socket-contact of a socket-outlet not possible while any other pin is accessible		P
	Compliance checked by manual test and by means of gauges with tolerances as specified in table 2		P
	Accessories with elastomeric or thermoplastic material: test carried out at $(35 \pm 2) ^\circ\text{C}$		P
	Socket-outlets with enclosure or bodies of rubber or polyvinyl chloride: test carried out with a force of 75 N for 1 min		P
	Fixed socket-outlets provided with metal covers or cover plates: clearance of at least 2 mm required between a pin and a socket-contact when another pin(s) is(are) in contact with the metal covers or cover plates (mm)..... :		N/A
10.4	External parts of plugs made of insulating material		N/A
	Overall dimensions of rings around pins not exceed 8 mm concentric with respect to the pin		N/A
10.5	Shuttered socket-outlets: live parts not accessible, without a plug in engagement, with the gauges shown in figure 9 and 10		N/A

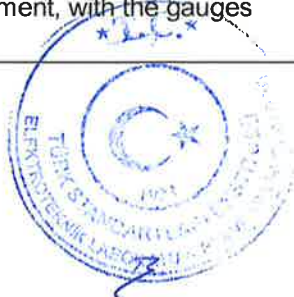

IEC 60884-1			
Clause	Requirement + Test	Result - Remark	Verdict
	Live contacts automatically screened when the plug is withdrawn		N/A
	Shutters so designed that a plug is inserted with the same movement in a socket outlet with shutters as in a socket-outlet without shutters		N/A
	Means cannot easily be operated by anything other than a plug and not depend upon parts which are liable to be lost		N/A
	Gauge of figure 9, applied to the entry holes corresponding to live contacts with a force of 20 N, for approximately 5 s, successively in three directions, does not touch live parts		N/A
	Steel gauge of figure 10, applied to the entry holes corresponding to live contacts with a force of 1 N for approximately 5 s, in three directions, does not touch live parts		N/A
	Accessories with elastomeric or thermoplastic material: test carried out at $(35 \pm 2) ^\circ\text{C}$		N/A
10.6	Earthing contacts of a socket-outlet designed that they cannot be deformed by the insertion of a plug		P
	Test plug inserted into the socket-outlet with a force of 150 N for 1 min		
10.6	Earthing contacts of a socket-outlet designed that they cannot be deformed by the insertion of a plug		P
	After this test: socket-outlet still comply with the requirements of clause 9		P
10.7	Socket-outlet with or without lid with increased protection: live parts not accessible		P
	Test wire of 1 mm diameter (figure 10) applied with a force of 1 N on all accessible surfaces does not touch live parts		P
	Accessories with elastomeric or thermoplastic material: test carried out at $(35 \pm 2) ^\circ\text{C}$		P
	Socket-outlet tested without a plug inserted with the lid, if any, open		P
<b>11</b>	<b>PROVISION FOR EARTHING</b>		
11.1	Earth connection made before the current-carrying contacts of the plug become live		P
	Current-carrying pins are separated before the earth connection is broken		P
11.2	Earthing terminals of rewirable accessories comply with clause 12		P
	Earthing terminals of the same size as the corresponding terminals for the supply conductors		P

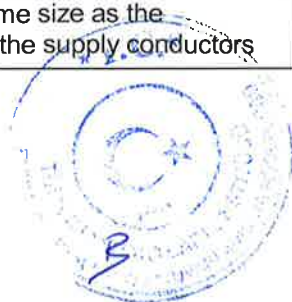



IEC 60884-1			
Clause	Requirement + Test	Result - Remark	Verdict
	Earthing terminals of rewirable accessories: internal		P
	Earthing terminals of fixed socket-outlets: fixed to the base or to a part reliably fixed to the base		P
	Earthing contacts of fixed socket-outlets:		
	- fixed to the base, or		P
	- fixed to the cover (reliably connected to the earthing terminals; contact pieces silver plated or with adequate protection)		N/A
	Parts of earthing circuit in one piece or reliably connected by riveting, welding, or the like		P
11.3	Accessible metal parts of fixed socket-outlets: permanently and reliably connected to the earthing terminal		N/A
11.4	Socket-outlets, having an IP>X0, with enclosure of insulating material and more than one cable inlet, provided with:		
	- an internal fixed earthing terminal, or		N/A
	- adequate space for a floating terminal (test connection using the type of terminal specified by the manufacturer), unless		N/A
	- earthing terminal of socket-outlet itself allows the connection of an incoming and an outgoing earthing conductor		P
11.5	Connection between earthing terminal and accessible metal parts: of low resistance		N/A
	Test current equal to 1,5 times the rated current or 25 A (A) .....		—
	Resistance not exceed 0,05 $\Omega$ ( $\Omega$ ) .....		N/A
11.6	Fixed socket-outlets according to item b) of 7.2.5: earthing socket contact and its terminal electrically separated from any metal mounting means or other exposed conductive parts which may be connected to the protective earthing circuit of the installation		N/A
<b>12</b>	<b>TERMINALS AND TERMINATIONS</b>		
	All the test on terminals, with the exception of the tests of 12.3 11 and 12.3.12, made after the test of clause 16		P
<b>12.1</b>	<b>General</b>		
12.1.1	Rewirable fixed socket-outlets provided with screw-type terminals or with screwless terminals .....		N/A
	Rewirable plugs and portable socket-outlets provided with terminals with screw clamping .....		P



IEC 60884-1			
Clause	Requirement + Test	Result - Remark	Verdict
	Pre-soldered flexible conductors used: pre-soldered area outside the clamp area of screw-type terminals		N/A
	Clamping means of terminals: not serve to fix any other components		P
12.1.2	Non-rewirable accessories provided with soldered, welded, crimped or equally effective permanent connections (termination) .....		N/A
	Screwed or Snap-On connections not used		N/A
	Connections made by crimping a pre-soldered flexible conductor not permitted		N/A
<b>12.2</b>	<b>Terminals with screw clamping for external copper conductors</b>		
12.2.1	Accessories provided with terminals which allows the proper connection of copper conductors as shows in table 3		P
	Rated current (A); Type of accessories .....	<b>16A</b>	—
	Type of conductor (rigid / flexible) .....	<b>Rigid</b>	—
	Smallest / largest cross-sectional area (mm <sup>2</sup> ) .....	<b>1,50 mm<sup>2</sup> / 2,50 mm<sup>2</sup></b>	—
	Diameter of the largest conductor (mm) .....		—
	Figure of terminal .....	<b>3</b>	—
	Minimum diameter D (minimum dimensions) of conductor space: required (mm); measured (mm) :	<b>2,00 mm ; &gt;2,00 mm</b>	P
12.2.2	Terminals allow the conductor to be connected without special preparation		P
12.2.3	Terminals have adequate mechanical strength		P
	Screws and nut for clamping the conductors have metric ISO thread or a comparable thread		P
	Screws not of soft metal such as zinc or aluminium		P
12.2.4	Terminals resistant to corrosion		P
12.2.5	Terminals clamp the conductor(s) without undue damage	See appended table 12.2.5	P
	During the test: conductor not slip out, no break near clamping unit and no damage		P
12.2.6	Terminals clamp the conductor reliably between metal surfaces	See appended table 12.2.6	P
	During the test: conductor not move noticeably		P
12.2.7	Terminals designed or placed that the conductor cannot slip out while the clamping screws or nuts are tightened	See appended table 12.2.7	P
	After the test: no wire of the conductor escaped from the clamping unit		P

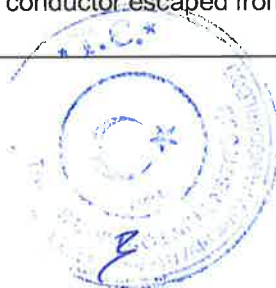

IEC 60884-1			
Clause	Requirement + Test	Result - Remark	Verdict
12.2.8	Terminals not work loose from their fixing to accessories		P
	Torque test (screws and nuts tightened and loosened 5 times):		
	- rated current (A) .....	16A	—
	- copper conductor of the largest cross-sectional area (mm <sup>2</sup> ) (table 3) .....	2,5 mm <sup>2</sup>	—
	- type of conductor (solid or stranded) .....	Solid	—
	- torque (Nm) (table 6 or appropriate figures 2, 3 or 4) .....	0,8 Nm	—
	During the test: terminals not work loose and show no damage		P
12.2.9	Clamping screws or nuts of earthing terminals: adequately locked against accidental loosening, not possible to loosen them without the aid of a tool		P
12.2.10	Earthing terminals: no risk of corrosion		P
	Body of brass or other metal no less resistant to corrosion		P
	The body is a part of a frame or enclosure of aluminium alloy: precautions are taken to avoid the risk of corrosion		N/A
12.2.11	Pillar terminals: distance <i>g</i> no less than the value specified in figure 2: required (mm); measured (mm) .....		N/A
	Mantle terminals: distance <i>g</i> no less than the value specified in figure 5: required (mm); measured (mm) .....		N/A
<b>12.3</b>	<b>Screwless terminals for external copper conductors</b>		
12.3.1	Screwless terminals of the type suitable for:		
	- for rigid copper conductors only, or		N/A
	- for both rigid and flexible copper conductors (tests carried out with rigid and then repeated with flexible conductors)		N/A
12.3.2	Screwless terminals provided with two clamping units each allowing the proper connection of rigid or of rigid and flexible conductors having nominal cross-sectional areas from 1,5 up to 2,5 mm <sup>2</sup> (table 7)		N/A
	Two conductors to be connected: each conductor introduced in a separate clamping unit		N/A
12.3.3	Screwless terminals allow the conductor to be connected without special preparation		N/A



IEC 60884-1			
Clause	Requirement + Test	Result - Remark	Verdict
12.3.4	Parts of screwless terminals intended for carrying current of materials as specified in 26.5		N/A
12.3.5	Screwless terminals clamp specified conductors with sufficient contact pressure without undue damage to the conductor		N/A
	Conductor clamped between metal surfaces		N/A
12.3.6	It is clear how the connection and disconnection of the conductors is to be made		N/A
	Disconnection of a conductor require an operation, other than a pull, so that can be made manually with or without a general-purpose tool		N/A
	It is not possible to confuse the opening intended for the use of a tool with the opening intended for the conductor		N/A
12.3.7	Screwless terminals intended for the interconnection of two or more conductors:		
	- the clamping of one of the conductors is independent of the clamping of the other conductor(s)		N/A
	- during the connection or disconnection the conductors can be connected or disconnected either at the same time or separately		N/A
	- each conductor introduced in a separate clamping unit.		N/A
	- it is possible to clamp securely any number of conductors up to the maximum as designed. Number of conductors; Nominal cross-sectional area (mm <sup>2</sup> ) .....		N/A
12.3.8	Screwless terminals of fixed socket-outlets: adequate insertion obvious and over-insertion prevented		N/A
12.3.9	Screwless terminals properly fixed to the socket-outlets		N/A
	Not work loose when conductors are connected or disconnected		N/A
	Self-hardening resins used to fix terminals not subject to mechanical stress		N/A
12.3.10	Screwless terminals withstand mechanical stresses occurring in normal use	See appended table 12.3.10	N/A
	During application of the pull conductor not come out of the terminal		N/A
	Additional test with apparatus shown in figure 11	See appended table 12.3.10	N/A
	During the test: conductors not moved noticeably in the clamping unit		N/A

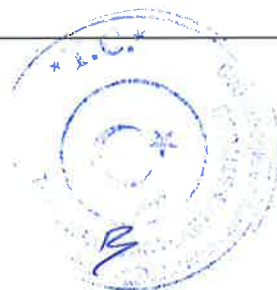

IEC 60884-1			
Clause	Requirement + Test	Result - Remark	Verdict
	After these tests: neither terminals nor clamping means have worked loose and conductors show no deterioration		N/A
12.3.11	Screwless terminals withstand electrical and thermal stresses occurring in normal use	See appended table 12.3.11	N/A
	After the test: inspection show no changes		N/A
	Repetition of mechanical strength test according to 12.3.10	See appended table 12.3.11	N/A
	During application of the pull conductor not come out of the terminal		N/A
	Additional test with apparatus shown in figure 11	See appended table 12.3.11	N/A
	During the test: conductors not moved noticeably in the clamping unit		N/A
	After these tests: neither terminals nor clamping means have worked loose and conductors show no deterioration		N/A
12.3.12	Screwless terminals: connected rigid solid conductor remains clamped, even when deflected during normal installation	See appended table 12.3.12	N/A
<b>13</b>	<b>CONSTRUCTION OF FIXED SOCKET-OUTLETS</b>		
13.1	Socket-contact assembly have sufficient resilience to ensure adequate contact pressure on plug pins		P
	Part of socket-contact assembly ensure metallic opposing contacts at least on two sides of each pins		P
13.2	Socket-contact and pin(s) of socket-outlet which are made of copper or copper alloy, as specified in 26.5, are considered as complying with this requirement		P
	The pin(s) of socket-outlets so constructed in such a way that the mechanical strength of the pin(s) does not depend on the plastic material		P
	Compliance is checked by inspection and in case of doubt by the tests of 14.2 and Clause 21 on a new set of specimens without plastic		P
13.3	Insulating linings, barriers and the like: adequate mechanical strength		P
13.4	Socket-outlets constructed as to permit		
	- easy introduction into the terminal and reliable connection of the conductors in the terminals, except for lead wires of pilot lights		P
	- easy fixing of the main part to a wall or in a mounting box		P
	- correct positioning of the conductors		P





IEC 60884-1			
Clause	Requirement + Test	Result - Remark	Verdict
	- adequate space between the underside of the main part and the surface on which the main part is mounted;		P
	- adequate space between the sides of the main part and the enclosure (cover or box);		P
	Socket-outlets having screwless terminals, constructed that the connecting and/or disconnecting means of the screwless terminals cannot be activated by the conductors during and after installation		N/A
	Compliance is checked by inspection and in case of doubt by the following test		N/A
	The test is carried out with a solid copper conductor having the smallest cross-sectional area, as specified in 12.3.2. (mm <sup>2</sup> ).....:		N/A
	If it is not possible to exert a force onto the connecting/disconnecting device, the product is deemed to comply with the requirements without further tests.		N/A
	During the application of the pull, the conductor do not come out of the screwless terminal		N/A
	In addition socket-outlets classified as design A: permit easy positioning and removal of the cover or cover plate, without displacing the conductors or activating the connecting and/or disconnecting means of screwless terminals.		P
	Compliance is checked by inspection and by an installation test with conductors of the largest nominal cross-sectional area specified in Table 3 (mm <sup>2</sup> ).....:		P
13.5	Socket-outlets designed that full engagement of associated plugs is not prevented by any projection from their engagement face		P
	Gap between the engagement face of the socket-outlet and the plug: not exceed 1 mm		P
13.6	Covers provided with bushings for the entry holes for the pins: not possible to remove them from the outside or for them to become detached inadvertently from the inside when the cover is removed		N/A
13.7	Covers, cover-plates or parts of them intended to ensure protection against electric shock:		
	- held in place at two or more points by effective fixings		P

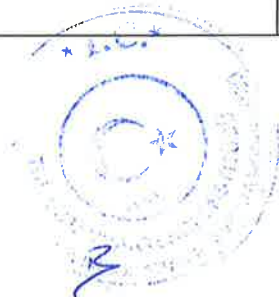



IEC 60884-1			
Clause	Requirement + Test	Result - Remark	Verdict
	- fixed by means of a single fixing, for example, by a screw, provided that they are located by another means (for example, by a shoulder)		N/A
	Fixings of covers or cover-plates of socket-outlets of design A serve to fix the main parts: there are means to maintain the base in position, even after removal of the covers or cover-plates		N/A
13.7.1	Covers or cover-plates whose fixings are of the screw-type:		
	Compliance checked by inspection only		P
13.7.2	Covers or cover-plates whose fixing is not dependent on screws and whose removal is obtained by applying a force in a direction approximately perpendicular to the mounting/supporting surface:		
	Compliance checked, when their removal may give access, with the standard test finger:		
	to live parts: by the test of 24.14 (verification of the non-removal and the removal)		N/A
	to non-earthed metal parts separated from live parts in such a way that creepage distances and clearances have the values shown in table 23: by the test of 24.15 (verification of the non-removal and the removal)		N/A
	only to parts of insulating material, or earthed metal parts, or metal parts separated from live parts in such a way that creepage distances and clearances have twice the values shown in table 23, or live parts of SEL V circuits not greater than 25 V a.c.: by the test of 24.16 (verification of the non-removal and the removal)		N/A
13.7.3	Covers or cover-plates the fixing of which is not dependent on screws and whose removal is obtained by using a tool, in accordance with the manufacturer's instructions given in an instruction sheet or in other documentation:		N/A
	Compliance checked, when their removal may give access, with the standard test finger:		N/A
	to live parts: by the test of 24.14 (verification of the non-removal only)		N/A
	to non-earthed metal parts separated from live parts in such a way that creepage distances and clearances have the values shown in table 23: by the test of 24.15 (verification of the non-removal only)		N/A



IEC 60884-1			
Clause	Requirement + Test	Result - Remark	Verdict
	only to parts of insulating material, or earthed metal parts, or metal parts separated from live parts in such a way that creepage distances and clearances have twice the values shown in table 23, or live parts of SEL V circuits not greater than 25 V a.c.: by the test of 24.16 (verification of the non-removal only)		N/A
13.8	Cover-plate intended for a socket-outlet with earthing contact: not interchangeable with a cover-plate intended for a socket-outlet without earthing contact		P
13.9	Surface-type socket-outlets: no free openings in their enclosures		P
13.10	Screws or other means for mounting the socket-outlet on a surface in a box or enclosure: easily accessible from the front		P
	Fixing means not serve any other fixing purpose		P
13.11	Multiple socket-outlets with a common base: provided with fixed links for the interconnection of the contacts in parallel		N/A
	Fixing of the links independent from the connection of the supply wires		N/A
13.12	Multiple socket-outlets, comprising separate bases: correct position of each base ensured		N/A
	Fixing of each base independent of the fixing of the combination to the mounting surface		N/A
13.13	Mounting plate of surface-type socket-outlets: adequate mechanical strength		P
13.14	Socket-outlets withstand the lateral strain imposed by equipment likely to be introduced into them		P
	Socket-outlets 16A 250V: test made 4 times with the socket-outlet turned through 90°, 5 N for 1 min (device shown in fig. 13)		P
	During the test: device not become disengaged from the socket-outlet		P
	After the test:		
	- no damage		P
	- socket-outlets comply with clause 22		P
13.15	Socket-outlets are not an integral part of lampholders		P
13.16	Surface-type socket-outlets having IP>20 are according to their IP classification when fitted with conduits or with sheathed cables and without a plug in engagement		P

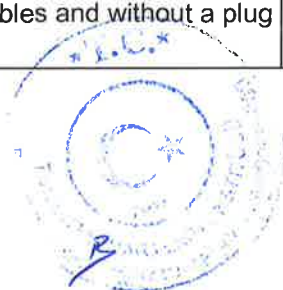

IEC 60884-1			
Clause	Requirement + Test	Result - Remark	Verdict
	Surface-type socket-outlets having IPX4 and IPX6 have provision for opening a drain hole		P
	Socket-outlets with a drain hole: drain hole is not less than 5 mm in diameter, or 20 mm <sup>2</sup> in area with a width and a length of not less than 3 mm .....		P
	Drain hole: effective		P
	Lid springs (if any): of corrosion-resistant material (bronze or stainless steel) .....		P
13.17	Earthing pins: adequate mechanical strength		N/A
	Not solid pins: compliance checked by inspection and by the test of 14.2 made after the tests of clause 21		N/A
13.18	Earthing contacts, phase contacts and neutral contacts :		
	- locked against rotation;		P
	- when the product is ready for the wiring do not possible to be removed without the use of a tool		P
13.19	Metal strips of the earthing circuit: no burrs which might damage the insulation of the supply conductors		P
13.20	Socket-outlets to be installed in a box: designed that the conductor ends can be prepared after the box is mounted in position, but before the socket-outlet is fitted in the box		P
13.21	Inlet openings: allow the introduction of the conduit or the sheath of the cable		P
	Surface-type socket-outlets:		
	the conduit or sheath of the cable can enter at least 1 mm into the enclosure		P
	inlet opening for conduit entries, or at least two of them if there are more than one, capable of accepting conduit sizes of 16, 20, 25 or 32 according to IEC 60423 or a combination of at least two of any of these sizes		P
	inlet opening for cable entries capable of accepting cables having the dimensions specified in table 14 or be as specified by the manufacturer: rated current (A); Limits of external dimensions of cable min/max (mm) .....		N/A
13.22	Membranes (grommets) in inlet openings: reliably fixed and not displaced by the mechanical and thermal stresses occurring in normal use		N/A
	Test on membranes subjected to the ageing treatment specified in 16.1 and assembled in the accessories		



IEC 60884-1			
Clause	Requirement + Test	Result - Remark	Verdict
	Accessories placed at $(40 \pm 2)$ °C for 2 h. Force of 30 N applied for 5 s by test probe 11 of IEC 61032. During the test: no deformation		N/A
	Membranes likely to be subjected to an axial pull: axial pull of 30 N applied for 5 s. During the test: membranes not become detached		N/A
	After the test: no harmful deformation, cracks or similar damage		N/A
	Test repeated with membranes not subjected to any treatment		N/A
13.23	Membranes in inlet openings: introduction of the cables into the accessory permitted when the ambient temperature is low		P
	Test on membranes not subjected to the ageing treatment specified in 16.1 and assembled in the accessories		
	Accessories kept at $(-15 \pm 2)$ °C for 2 h: possibility to introduce cables of the largest diameter through membranes		P
	After the test: no harmful deformation, cracks or similar damage		P
<b>14</b>	<b>CONSTRUCTION OF PLUGS AND PORTABLE SOCKET-OUTLETS</b>		
14.1	Non-rewirable portable accessories:		
	flexible cable cannot be separated from the accessory without making it permanently useless		N/A
	Accessory cannot be opened by hand or by using a general purpose tool, for example a screwdriver used as such		N/A
14.2	Pins of portable accessories: adequate mechanical strength		
	Test for pins not solid (made after clause 21): force of 100 N exerted on the pin, according to figure 14, for 1 min by means of a steel rod $\varnothing 4,8$ mm		N/A
	During the application of the force: reduction of the dimension of the pin not exceed 0,15 mm		N/A
	After removal of the rod: dimensions of the pin not changed by more than 0,06 mm		N/A
14.3	Pin(s) and contacts of portable accessories :		
	- locked against rotation;		N/A
	- not removable without dismantling the plug;		N/A
	- adequately fixed in the body of the plug		N/A
	Earthing or neutral pins or contacts of plugs: not possible to arrange in an incorrect position		N/A

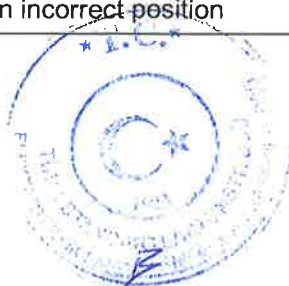

IEC 60884-1			
Clause	Requirement + Test	Result - Remark	Verdict
	The pin(s) of portable accessories constructed in such a way that the mechanical strength of the pin(s) does not depend on the plastic material		N/A
	Compliance is checked by inspection and in case of doubt by the tests of 14.2 and Clause 21 on a new set of specimens without plastic		N/A
	Surfaces of plug pin(s) smooth and free from burrs or sharp edges and other irregularities which could cause damage or excessive wear to corresponding socket contacts or shutters		N/A
14.4	Earthing contacts, phase contacts and neutral contacts of portable socket-outlets :		
	- locked against rotation		N/A
	- removable only with the aid of a tool, after dismantling the socket-outlet		N/A
	In addition, for single portable socket-outlets compliance is checked by the test of 24.2		N/A
14.5	Socket-contact assemblies: sufficient resilience		N/A
	Parts of socket-contact assemblies:		
	- are not of insulating material except ceramic, or other material with no less suitable characteristics		N/A
	- ensure metallic contacts at least on two opposing sides of each pin		N/A
	Contact pressure of the contact tube does not depend on soldered connection only		N/A
14.6	Pins and socket-contacts: resistant to corrosion and abrasion		N/A
	Socket contacts and pin(s) of socket-outlets, which are made of copper or copper alloy, as specified in 26.5, are considered as complying with this requirement.		N/A
14.7	Enclosures of rewirable portable accessories: completely enclose terminals and ends of flexible cable		N/A
	Construction is unlikely that:		
	- cores not pressed against each other causing damage		N/A
	- cores of live conductor not pressed against accessible metal parts		N/A
	- core of earthing conductor not pressed against live parts		N/A





IEC 60884-1			
Clause	Requirement + Test	Result - Remark	Verdict
14.8	Rewirable portable accessories: terminal screws or nuts cannot become loose and fall out of position and establish an electrical connection between live parts and earthing terminal or metal parts		N/A
14.9	Rewirable portable accessories with earthing contact: ample space for slack of earthing (test)		N/A
	Non-rewirable non-moulded-on accessories with earthing contact: current-carrying conductors stressed before the earthing conductor if the flexible cable slips in its anchorage		N/A
14.10	Terminals of rewirable portable accessories and terminations of non-rewirable portable accessories: located and shielded that loose wires not present a risk of electric shock		N/A
	Non-rewirable moulded-on portable accessories: provided with means to prevent loose wires of a conductor from reducing the minimum isolation distance requirements		N/A
14.10.1	Rewirable accessories: test with 6 mm free wire		
	free wire of a conductor connected to a live terminal not touch any accessible metal part or able to emerge from the enclosure		N/A
	free wire of a conductor connected to an earthing terminal not touch a live part		N/A
14.10.2	Non-rewirable, non-moulded-on accessories: test with a free wire of length equivalent to the maximum designed stripping length declared by the manufacturer plus 2 mm		N/A
	free wire of a conductor connected to a live termination not touch any accessible metal part or reduce creepage distance and clearance below 1,5 mm to the external surface		N/A
	free wire of a conductor connected to an earth termination not touch any live part		N/A
14.10.3	Non-rewirable, moulded-on accessories:		N/A
	Verification of means to prevent stray wires reducing the minimum distance through insulation to external accessible surface below 1,5 mm		N/A
14.11	Rewirable portable accessories:		
	- clear how relief from strain and prevention of twisting is intended to be effected		N/A
	- cord anchorage, or at least part of it, integral with or securely fixed to one of the component parts of the plug or portable socket-outlet		N/A
	- makeshift methods not used		N/A

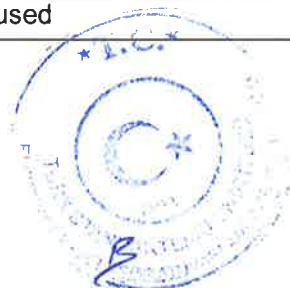



IEC 60884-1			
Clause	Requirement + Test	Result - Remark	Verdict
	- cord anchorage suitable for the different types of flexible cable which may be connected to it; screws, if any: not serve to fix any other component		N/A
	- cord anchorages: of insulating material or provided with an insulating lining fixed to the metal parts		N/A
	- metal parts of cord anchorages, including clamping screws: insulated from the earthing circuit		N/A
14.12	Rewirable portable accessories and non-rewirable non-moulded on portable accessories: it is not possible to remove covers, cover-plates or parts of them intended to ensure protection against electric shock without the use of a tool		N/A
14.13	Covers of portable socket-outlets: bushings for entry holes for the pins not removable from the outside or detachable inadvertently from the inside		N/A
14.14	Screws intended to allow access to interior of the accessory: captive		N/A
14.15	Engagement face of plugs: no projections		N/A
14.16	Engagement face of portable socket-outlets: no projection		N/A
14.17	Portable accessories of IP>20: enclosed according to their IP classification		N/A
	Plugs having IP>20: adequately enclosed with the exception of the engagement face		N/A
	Portable socket-outlets having IP>20: adequately enclosed without a plug in engagement		N/A
	Lid springs (if any): of corrosion-resistant material (bronze or stainless steel) .....		N/A
14.18	Portable socket-outlets: means for suspension from a wall or other mounting surfaces not allow access to live parts		N/A
	No free openings between space intended for suspension means by which the socket-outlet is fixed to the wall, or other mounting surface and live parts		N/A
14.19	Combinations of portable accessories and switches, circuit-breakers or other devices comply with relevant individual IEC standards, if relevant combined product standard does not exist .....		N/A
14.20	Portable accessories: not integral part of lampholders		N/A
14.21	Plugs for equipment of class II:		N/A
	- rewirable or non-rewirable		N/A

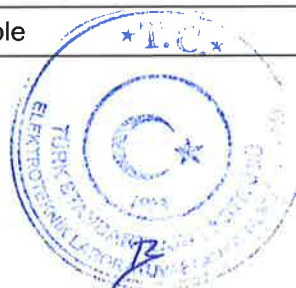

IEC 60884-1			
Clause	Requirement + Test	Result - Remark	Verdict
	- if part of a cord set: provided with a connector for equipment of class II		N/A
	- if part of a cord extension set: provided with a portable socket-outlet for equipment of class II		N/A
14.22	Components (switches and fuses) incorporated in accessories: comply with the relevant IEC standard as far as it applies		N/A
	Components incorporated in portable accessories so rated, or so protected, that overloading of either the component or the plug or the socket-outlet portion cannot occur in normal use		N/A
	Requirements for switches incorporated in portable accessories are detailed in Annex D	See appended table 14.22	N/A
	For portable socket-outlets and rewirable plugs the incorporated overcurrent protective device in the accessory shall have a rated current equal to or less than the rated current of the accessory		N/A
	Any other component(s), such as switches or control devices, have a rated current not less than (rated current referred to resistive load):		N/A
	- the rated current of the accessory or		
	- the rated current of the incorporated overcurrent protective device, if any		N/A
	For non-rewirable plugs, any other incorporated component(s), such as switches or control devices, have a rated current not less than:		N/A
	- the test current for the combination of the accessory and the cable as indicated in Table 20, for Clause 21, or		N/A
	- the rated current of the incorporated overcurrent protective device, if any		N/A
	Any incorporated component(s) have a rated voltage not less than the rated voltage of the accessory		N/A
	Compliance is checked by inspection and, if necessary, by testing the component according to the relevant IEC standard		N/A
14.23	Plug-in equipment: not cause overheating of the pins or impose undue strain		N/A
	Plugs with rating above 16 A and 250 V: not integral part of other equipment		N/A
	Tests for two-pole plugs, with or without earthing contact, with rating up to and including 16 A and 250 V (plug of equipment inserted into a fixed socket-outlet complying with this standard):		N/A
14.23.1	Socket-outlet connected to a supply voltage equal to 1,1 times the highest rated voltage of the equipment (V) .....		—

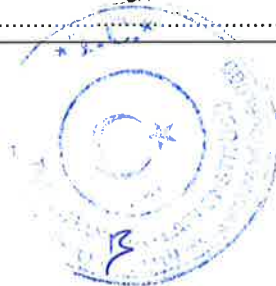

IEC 60884-1			
Clause	Requirement + Test	Result - Remark	Verdict
	Temperature rise of the pins after 1 h not exceed 45 K (K) .....		N/A
14.23.2	Additional torque applied to the socket-outlet in order to maintain the engagement face in the vertical plane not exceed 0,25 Nm (Nm) .....		N/A
14.24	Plugs can easily be withdrawn by hand from the relevant socket-outlets		N/A
	Gripping surfaces are so designed that the plug can be withdrawn without having to pull the flexible cable		N/A
14.25	Membranes in inlet openings of portable accessories: meet the requirements of 13.22 and 13.23		N/A
14.26	Rewirable portable socket-outlets which can be assembled and wired for normal use after their rear part has been fixed onto a surface comply both with the requirements for portable socket-outlets and with the following additional requirements for surface fixed socket-outlets:		N/A
	- provision for earthing: 11.2, 11.3, 11.6;		N/A
	- terminals and terminations: 12.2.1;		N/A
	- construction of fixed socket-outlets: Clause 13;		N/A
	- resistance to ageing, protection provided by enclosures, and resistance to humidity: 16.2.1, 16.2.2;		N/A
	- temperature rise: Clause 19;		N/A
	- mechanical strength: Clause 24;		N/A
	- resistance to heat: Clause 25;		N/A
	- creepage distances, clearances and distances through sealing compound: Clause 27;		N/A
	- resistance of insulating material to abnormal heat, to fire and to tracking: 28.1.1, glow-wire test		N/A
<b>15</b>	<b>INTERLOCKED SOCKET-OUTLETS</b>		
	Socket-outlet interlocked with a switch:		N/A
	plug cannot be inserted into or completely withdrawn from the socket-outlet while the socket-contacts are live		N/A
	socket-contacts cannot be made live until a plug is almost completely in engagement		N/A
<b>16</b>	<b>RESISTANCE TO AGEING, PROTECTION PROVIDED BY ENCLOSURES, AND RESISTANCE TO HUMIDITY</b>		
<b>16.1</b>	<b>Resistance to ageing</b>		
	Accessories are resistant to ageing		P

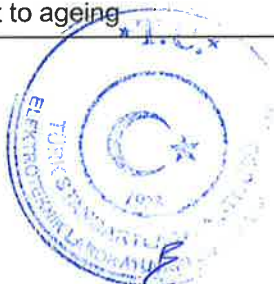

IEC 60884-1			
Clause	Requirement + Test	Result - Remark	Verdict
	For accessories having a lid, the lid is closed during the test		P
	Portable socket-outlets: the plug of the same system having the same rated current as the socket-outlet inserted into the socket-outlet during the test		N/A
	Accessories subjected to a test in a heating cabinet at $(70 \pm 2) ^\circ\text{C}$ for seven days (168 h)		P
	After the tests, the specimens show:		
	- no crack visible with normal or corrected vision without additional magnification		P
	- no sticky or greasy material		P
	- no trace of cloth (forefinger pressed with 5 N)		P
	- no damage		P
	Portable socket-outlets: contact pressure of the contact assembly checked as specified in subclause 22.2 with the single-pin gauge		N/A
<b>16.2</b>	<b>Protection provided by enclosures</b>		
	Enclosures provide a degree of protection in accordance with the IP designation of the accessory	IP54	P
<b>16.2.1</b>	<b>Protection against access to hazardous parts and against harmful effects due to ingress of solid foreign objects</b>		
	Accessories and their enclosures provide a degree of protection against access to hazardous parts and against harmful effects due to ingress of solid foreign objects	IP54	P
	Fixed socket-outlets: mounted as in normal use on a vertical surface	IP54	P
	Flush-type and semi-flush type socket-outlets: mounted in an appropriate box according to the manufacturer's instructions		N/A
	Accessories with screwed glands or membranes fitted with flexible cables within the range specified in table 3:		
	- largest cross-sectional area (mm <sup>2</sup> ); type of cable (table 17) .....		—
	- smallest cross-sectional area (mm <sup>2</sup> ); type of cable (table 17) .....		—
	Glands tightened with a torque equal to 2/3 of the torque applied during the test of 24.6 (Nm) .....		—
	Screws of the enclosure tightened with a torque equal to 2/3 of the torque given in table 6 (Nm) ...		—

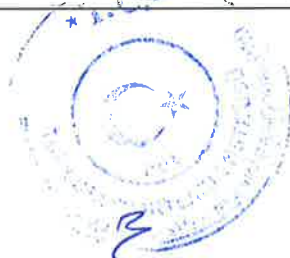

IEC 60884-1			
Clause	Requirement + Test	Result - Remark	Verdict
<b>16.2.1.1</b>	<b>Protection against access to hazardous parts</b>		
	Appropriate test performed as specified in IEC 60529 (see also clause 10)	IP54	P
<b>16.2.1.2</b>	<b>Protection against harmful effects due to ingress of solid foreign objects</b>		
	Appropriate test performed as specified in IEC 60529	IP54	P
	Test on accessories with IP5X (considered to be of category 2): dust not penetrated in a quantity to interfere with satisfactory operation or to impair safety	IP54	P
	Test on accessories with IP6X (considered to be of category 1): dust do not penetrate		N/A
<b>16.2.2</b>	<b>Protection against harmful effects due to ingress of water</b>		
	Accessories and their enclosures provide a degree of protection against harmful effects due to ingress of water in accordance with their IP classification	IP54	P
	Appropriate test performed as specified in IEC 60529 under the following conditions:		
	Flush-type and semi-flush type socket-outlets: fixed in a vertical test wall using an appropriate box according to the manufacturer's instructions		N/A
	Accessory suitable to be installed on a rough wall: test wall according to figure 15 is used		N/A
	Surface-type socket-outlets mounted as for normal use in a vertical position and fitted with cables (having conductors of the largest and smallest nominal cross-sectional area given in table 3) or conduits or both in accordance with the manufacturer's instructions:		P
	- largest cross-sectional area (mm <sup>2</sup> ); type of cable (table 17) .....		—
	- smallest cross-sectional area (mm <sup>2</sup> ); type of cable (table 17) .....		—
	Portable socket-outlets tested on a plain, horizontal surface in a position as in normal use and fitted with flexible cables (having conductors of the largest and smallest nominal cross-sectional area given in table 3) according to table 17:		N/A
	- largest cross-sectional area (mm <sup>2</sup> ); type of cable (table 17) .....		—
	- smallest cross-sectional area (mm <sup>2</sup> ); type of cable (table 17) .....		—
	Screws of enclosure tightened with a torque equal to 2/3 of the torque given in table 6 (Nm) .....		—
	Glands tightened with a torque equal to 2/3 of the torque applied during the test of 24.6 (Nm) .....		—





IEC 60884-1			
Clause	Requirement + Test	Result - Remark	Verdict
	Accessory with drain holes opened during the test: any accumulation of water proved by inspection		P
	Socket-outlets tested without a plug in engagement		P
	Plugs tested when in full engagement with:		
	- a fixed socket-outlets		P
	- a portable socket-outlets		N/A
	of the same system and with the same degree of protection against harmful effects due to ingress of water		—
	Specimens withstand an electric strength test specified in 17.2 which is started within 5 min of completion of the IP test		P
<b>16.3</b>	<b>Resistance to humidity</b>		P
	Accessories proof against humidity which may occur in normal use		P
	Compliance checked by a humidity treatment carried out in a humidity cabinet containing air with relative humidity maintained between 91 % and 95 %		P
	Specimens kept in the cabinet for:		
	- two days (48 h) for accessories having IPX0		N/A
	- seven days (168 h) for accessories having IP>X0		P
	After this treatment the specimens show no damage		P
<b>17</b>	<b>INSULATION RESISTANCE AND ELECTRIC STRENGTH</b>		
17.1	Insulation resistance measured 1 min after application of 500 V d.c.	See appended table 17.1	P
17.2	Electric strength: a.c. test voltage applied for 1 min	See appended table 17.2	P
<b>18</b>	<b>OPERATION OF EARTHING CONTACTS</b>		
	Earthing contacts provide adequate contact pressure and not deteriorate in normal use		P
	Compliance checked by the tests of clauses 19 and 21		P
<b>19</b>	<b>TEMPERATURE RISE</b>		
	Accessories constructed that they comply with the following temperature rise test		P
	Non-rewirable accessories are tested as delivered		N/A
	In the case of multiple socket-outlets, the test is carried out on one socket-outlet of each type and current rating with the test current as specified in Table 20 passed through that one socket-outlet	See appended tables	P





IEC 60884-1			
Clause	Requirement + Test	Result - Remark	Verdict
	The temperature rise of the terminals, terminations and clamping units according to Figure 44 determined by means of thermocouples do not exceed 45 K	See appended tables	P
19.1	Socket-outlets and plugs are tested as follows:		
	Socket-outlets tested using a test plug with brass pins having the minimum specified dimensions	See appended table 19.1	P
	For this test the temperature rise is measured on the terminals and terminations.		P
	Plugs tested with clamping units having dimensions specified in Figure 44 fitted on each live pin and earthing pin, if any	See appended table 19.1	N/A
	Plugs having lateral earthing contacts and resilient earthing contacts tested using a fixed socket-outlet complying with the standard and having as near to-average characteristics as can be selected, but with minimum size of the earthing pin, if any	See appended table 19.1	N/A
19.2	Fixed socket-outlets of a socket-outlet and fused plug system are tested as follows:		
	a) For a single socket-outlet the plug is inserted into the socket-outlet and 70 % of the test current is passed through the plug	See appended table 19.2	N/A
	The balance of the total test current is passed, simultaneously through a looped connection, connected to the socket-outlet terminals		N/A
	The total nominal load on the supply cable is passed for 60 min	See appended table 19.2	N/A
	b) For a multiple socket-outlet a plug is inserted into one socket-outlet and 70 % of the test current is passed	See appended table 19.2	N/A
	A second plug is inserted into another socket-outlet and the balance of the total test current is passed simultaneously through this plug.....:	See appended table 19.2	N/A
	The total nominal load on the supply cable is passed for 60 min.	See appended table 19.2	N/A
19.3	Portable socket-outlets and rewirable plugs with incorporated components are tested by the following two tests:		
	– with a current which is equal to the test current as indicated in Table 20, for Clause 19	See appended table 19.3	N/A
	– with a current which is equal to the rated current of the portable accessory or the rated current of the component(s), whichever is the lower	See appended table 19.3	N/A
	Non-rewirable plugs with incorporated components are tested by the following two tests:		N/A



IEC 60884-1			
Clause	Requirement + Test	Result - Remark	Verdict
	– with a current which is equal to the test current for the combination of the plug and the cable as indicated in Table 20, for Clause 19	See appended table 19.3	N/A
	– with a current which is equal to the test current for the combination of the plug and the cable as indicated in Table 20, for Clause 21, or the rated current of the component(s), whichever is the lower	See appended table 19.3	N/A
<b>20</b>	<b>BREAKING CAPACITY</b>		
	Accessories have adequate breaking capacity		P
	Compliance checked by testing:		
	- socket-outlets;	See appended table 20	P
	- plugs with pins which are not solid	See appended table 20	N/A
	Multiple socket-outlets: test carried out on one socket-outlet of each type and current rating		P
	During the test: no sustained arcing occur		P
	After the test:		
	- specimens show no damage impairing their further use;		P
	- entry holes for the pins not show any damage which may impair the safety		P
<b>21</b>	<b>NORMAL OPERATION</b>		
	Accessories withstand without excessive wear or other harmful effect, the mechanical, electrical and thermal stresses occurring in normal use		P
	Compliance checked by testing:		
	- socket-outlets;	See appended table 21	P
	- plugs with resilient earthing socket-contacts;	See appended table 21	N/A
	- plugs with pins which are not solid	See appended table 21	N/A
	Test performed according to the procedure specified in Figure 43; point of Figure 43 at which the test program has begun (1, 2, 3) .....		—
	Test current passed:		
	- during each insertion and withdrawal of the plug ( $I_n \leq 16A$ )		P
	- during alternate insertion and withdrawal, the other insertion and withdrawal being made without current flowing ( $I_n > 16A$ )		N/A
	Multiple socket-outlets: test carried out on one socket-outlet of each type and current rating		P
	During the test: no sustained arcing occur.		P

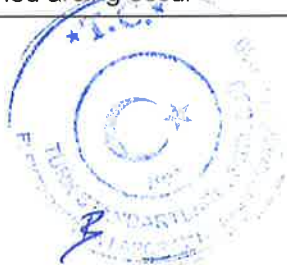

IEC 60884-1			
Clause	Requirement + Test	Result - Remark	Verdict
	After the test the specimens do not show:		
	- wear impairing their further use;		P
	- deterioration of enclosures, insulating lining or barriers;		P
	- damage to the entry holes for the pins, that might impair proper working;		P
	- loosening of electrical or mechanical connections;		P
	- seepage of sealing compound		N/A
	Shuttered socket-outlets: gauges of figure 9 and 10 applied to the entry holes corresponding to live contacts do not touch live parts when they remain under the relevant forces	See appended table 21	N/A
	Temperature-rise test (requirements of clause 19)	See appended table 21	P
	Electric strength (sub-clause 17.2)	See appended table 21	P
	Pins which are not solid: test according to 14.2		N/A
<b>22</b>	<b>FORCE NECESSARY TO WITHDRAW THE PLUG</b>		
	Construction of accessory does allow the easy insertion and withdrawal of the plug, and prevent the plug from working out of the socket-outlet in normal use		P
<b>22.1</b>	<b>Verification of the maximum withdrawal force</b>	See appended table 22	P
<b>22.2</b>	<b>Verification of the minimum withdrawal force</b>	See appended table 22	P
<b>23</b>	<b>FLEXIBLE CABLES AND THEIR CONNECTIONS</b>		
23.1	Rewirable plugs and rewirable portable socket-outlets are provided with a cord anchorage		N/A
	Sheath of flexible cable is clamped within the cord anchorage		N/A
	In non-rewirable plugs and non-rewirable portable socket-outlets the cable is maintained in position and the terminations are relieved from strain and twisting		N/A
	Sheath of flexible cable is maintained inside the accessory		N/A
23.2	Pull and torque test		
	Non-rewirable accessories:		
	After the test: displacement $\leq 2$ mm	See appended table 23.2	N/A
	No break in the electrical connections		N/A
	Rewirable accessories:		

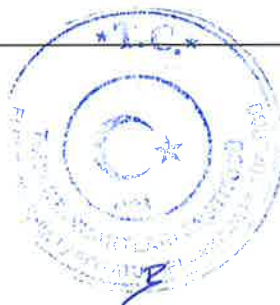

IEC 60884-1			
Clause	Requirement + Test	Result - Remark	Verdict
	After the test: displacement $\leq 2$ mm	See appended table 23.2	N/A
	End of conductors not have moved noticeably in the terminals		N/A
	Rewirable accessories having rated current up to and including 16 A:		
	Suitable for fitting with the appropriate cable as shown in table 19		N/A
	Type of flexible cable; number of conductors and nominal cross-sectional area (mm <sup>2</sup> ).....:		—
23.3	Non-rewirable plugs and non-rewirable portable socket-outlets are provided with a flexible cable complying with IEC 60227 or IEC 60245		N/A
	Flexible cables have the same number of conductors as there are poles in the plug or socket-outlet		N/A
	Conductor connected to the earthing contact is identified by the colour combination green/yellow		N/A
23.4	Non-rewirable plugs and non-rewirable portable socket-outlets: designed that the flexible cable is protected against excessive bending		N/A
	Guards of insulating material and fixed in reliable manner		N/A
	Flexing test (10.000 flexings)		
	During the test: no interruption of the test current and no short-circuit between conductors	See appended table 23.4	N/A
	After the test: guard no separated from the body, insulation shows no sign of abrasion or wear, broken strands become no accessible	See appended table 23.4	N/A
<b>24</b>	<b>MECHANICAL STRENGTH</b>		
	Accessories, surface mounting boxes, screwed glands and shrouds have adequate mechanical strength		P
24.1	Fixed socket-outlets, portable multiple socket-outlets and surface-type mounting boxes: hammer test described in IEC 60068-2-75 (test EHA), equivalent mass of 250 g	See appended table 24.1	P
	After the test: no damage, live parts no become accessible		P
24.2	Portable single socket-outlets and plugs: subjected to test Ec: Rough handling shocks, primarily for equipment-type specimens, procedure 2 of IEC 60068-2-31 (tumbling barrel); number of falls.....:		N/A
	After the test:		

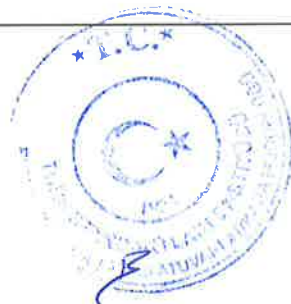

IEC 60884-1			
Clause	Requirement + Test	Result - Remark	Verdict
	- no part become detached or loosened;		N/A
	- pins no become so deformed that the plug cannot be introduced into a socket-outlet and also fails to comply with the requirements of 9.1 and 10.3;		N/A
	- pins no turn when a torque of 0,4 Nm is applied for 1 min in each direction		N/A
	The shutters of socket-outlets tested again according to Clause 21, from paragraph 19 up to paragraph 24 (only the tests of shutters)		N/A
24.3	Main parts of surface-type socket-outlets: first fixed to a cylinder of rigid steel sheet and then fixed to a flat steel sheet		P
	During and after the tests: no damage		P
24.4	Portable single socket-outlets, multiple socket-outlets and plugs (elastomeric or thermoplastic material): impact test, weight (1000 ± 2) g, height 100 mm (apparatus shown in fig. 27)		N/A
	Specimens placed in a freezer at (-15 °C ± 2) °C for at least 16 h. After the test: no damage		N/A
24.5	Portable single socket-outlets and plugs (elastomeric or thermoplastic material): compression test, 300 N for 1 min, position a) and b) (apparatus shown in fig. 8)		N/A
	After the test: no damage		N/A
24.6	Screwed glands of accessories having IP>20: torque test (1 min)		N/A
	- diameter of test rod (mm) .....		—
	- type of material (metal / moulded).....		—
	- torque (Nm) .....		—
	After the test: no damage of glands and enclosures of the specimens		N/A
24.7	Plug pins provided with insulating sleeves: 20000 movements, 4 N (apparatus shown in fig. 28)		N/A
	After the test: no damage of pins, insulating sleeve not have punctured or rucked up		N/A
24.8	Shuttered socket-outlets: mechanical test carried out on specimens submitted to the normal operation test according to clause 21		N/A
	Force (40 N / 75 N) applied for 1 min against the shutter of an entry hole by means of one pin (N) :		—
	Pin did not come in contact with live parts		N/A
	After the test: no damage		N/A
24.9	Mechanical test for multiple portable socket-outlet: 8 falls on concrete floor with the specimens arranged as shown in figure 29		





IEC 60884-1			
Clause	Requirement + Test	Result - Remark	Verdict
	Rewirable multiple socket-outlets: flexible cable of the smallest cross-sectional area specified in table 3 .....	0,75 mm <sup>2</sup>	—
	After the test: no damage, no part have become detached or loosened		N/A
	Accessories having IP>X0 submitted again to the tests as specified in 16.2		N/A
	The shutters of multiple socket-outlets tested again according to Clause 21, from paragraph 19 up to paragraph 24 (only the tests of shutters)		N/A
24.10	Plugs: pull test to verify the fixation of pins in the body of the plug (new specimens)		
	Maximum withdrawal force (table 16) applied for 1 min on each pin in turn, after the specimen has been placed at (70 ± 2) °C for 1 h (N) .....		—
	After the test: displacement of pins in the body of the plug ≤ 1 mm (mm) .....		N/A
24.11	Barriers of portable socket-outlets having means for suspension on a mounting surface:		
	Force applied for 10 s against the barrier by means of a cylindrical steel rod (1,5 times the maximum plug withdrawal force in 22.1, table 16) (N) .....		—
	Rod did not pierce the barrier		N/A
24.12	Portable socket-outlets having means for suspension on a mounting surface (pull test):		
	Pull applied to the supply flexible cable for 10 s (force prescribed in 23.2 for checking the flexible cable anchorage) (N) .....		—
	During the test: no break of the means for suspension on a mounting surface		N/A
24.13	Portable socket-outlets having means for suspension on a mounting surface (pull test):		
	Pull applied to the engagement face of the socket-outlet for 10 s (maximum withdrawal force specified, for the corresponding plug, in table 16) (N) .....		—
	During the test: no break of the means for suspension on a mounting surface		N/A
24.14	Forces necessary to retain or remove covers, cover-plates or parts of them (accessibility with the test finger to live parts)		
24.14.1	Verification of the retention of covers or cover-plates (fixed socket-outlets)		
	Force (40 N / 80 N) applied for 1 min perpendicular to the mounting surface (N) .....		—



IEC 60884-1			
Clause	Requirement + Test	Result - Remark	Verdict
	Covers or cover-plates did not come off		P
	Test repeated on new specimens with a sheet of hard material, (1 ± 0,1) mm thick, fitted around the supporting frame (fig. 31): covers or cover-plates did not come off		N/A
	After the test: no damage		N/A
24.14.2	Verification of the removal of covers or cover-plates (fixed socket-outlets)		
	Force not exceeding 120 N applied 10 times perpendicular to the mounting / supporting surface: covers or cover-plates came off		P
	Test repeated on new specimens with a sheet of hard material, (1 ± 0,1) mm thick, fitted around the supporting frame (fig. 31): covers or cover-plates came off		N/A
	After the test: no damage		N/A
24.14.3	Verification of the retention of covers or cover-plates (plugs and portable socket-outlets)		
	Force 80 N applied for 1 min perpendicular to the mounting surface: covers, cover-plates or parts of them did not come off		N/A
	Test repeated with a force of 120 N:		N/A
	Rewirable plugs and rewirable portable socket-outlets: covers, cover-plates or parts of them came off but the specimen showed no damage		N/A
	Non-rewirable, non-moulded-on accessories: covers, cover-plates or parts of them came off but the accessories were permanently useless according to 14.1		N/A
24.15	Force necessary for covers or cover-plates to come off or not to come off (accessibility with the test finger to non-earthed metal parts separated from live parts by creepage distances and clearances according to table 23)		N/A
24.14.1	Verification of the non-removal of covers or cover-plates		N/A
	Force (10 N / 20 N) applied for 1 min in direction perpendicular to the mounting surface (N) .....		—
	Covers or cover-plates did not come off		N/A
	Test repeated on new specimens with a sheet of hard material, 1 mm ± 0,1 mm thick, fitted around the supporting frame (fig. 31): covers or cover-plates did not come off		N/A
	After the test: no damage		N/A
24.14.2	Verification of the removal of covers or cover-plates		N/A



IEC 60884-1			
Clause	Requirement + Test	Result - Remark	Verdict
	Force not exceeding 120 N applied 10 times in direction perpendicular to the mounting / supporting surface: covers or cover-plates came off		N/A
	Test repeated on new specimens with a sheet of hard material, 1 mm ± 0,1 mm thick, fitted around the supporting frame (fig. 31): covers or cover-plates came off		N/A
	After the test: no damage		N/A
24.16	Force necessary for covers or cover-plates to come off or not to come off (accessibility to insulating parts, earthed metal parts, live parts of SELV ≤ 25 V a.c. or metal parts separated from live parts by creepage distances twice those according to table 23)		N/A
24.14.1	Verification of the non-removal of covers or cover-plates		N/A
	Force 10 N applied for 1 min in direction perpendicular to the mounting surface: covers or cover-plates did not come off		N/A
	Test repeated on new specimens with a sheet of hard material, 1 mm ± 0,1 mm thick, fitted around the supporting frame (fig. 31): covers or cover-plates did not come off		N/A
	After the test: no damage		N/A
24.14.2	Verification of the removal of covers or cover-plates		
	Force not exceeding 120 N applied 10 times in direction perpendicular to the mounting / supporting surface: covers or cover-plates came off		N/A
	Test repeated on new specimens with a sheet of hard material, 1 mm ± 0,1 mm thick, fitted around the supporting frame (fig. 31): covers or cover-plates came off		N/A
	After the test: no damage		N/A
24.17	Test with gauge of figure 7 applied according to figure 9 for verification of the outline of covers or cover-plates: distances between face C of gauge and outline of side under test, not decrease .....	complying / not complying	—
24.18	Test with gauge according to figure 5 applied as shown in figure 11 (1 N): gauge not enter more than 1mm .....	complying / not complying	—
24.19	Shroud of portable socket-outlets: compression test (20 ± 2) N at (25 ± 5) °C by means of the apparatus shown in figure 38		
	After 1 min and while the shrouds are still under pressure the dimensions did comply with the appropriate standard sheet		N/A
	Test repeated with the specimen rotated 90 °		N/A

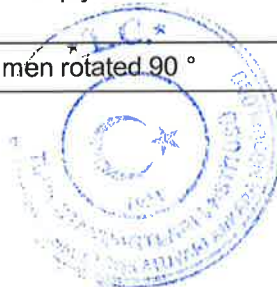

*[Handwritten signature]*

IEC 60884-1			
Clause	Requirement + Test	Result - Remark	Verdict
<b>25</b>	<b>RESISTANCE TO HEAT</b>		
25.1	Specimens kept for 1 h in a heating cabinet at $(100 \pm 2)$ °C for 1 h		
	During the test: no change impairing their further use and sealing compound, if any, not flow		P
	After the test:		
	- no access to live parts with probe B of IEC 61032 applied with a force not exceeding 5 N		P
	- markings still legible		P
25.2	Parts of insulating material necessary to retain current-carrying parts and parts of the earthing circuit in position, as well as parts of the front surface zone, 2 mm wide, surrounding the phase and neutral pin entry holes: ball-pressure test at $(125 \pm 2)$ °C for 1 h	See appended table 25.2	P
25.3	Parts of insulating material not necessary to retain current-carrying parts and parts of the earthing circuit in position, even though in contact with them: ball-pressure test (1 h)	See appended table 25.3	P
25.4	Portable accessories: compression test (20 N) at $(80 \pm 2)$ °C for 1 h by means of the apparatus shown in figure 38		N/A
	After the test: no damage		N/A
<b>26</b>	<b>SCREWS, CURRENT-CARRYING PARTS AND CONNECTIONS</b>		
26.1	Connections withstand mechanical stresses		P
	Thread-forming or thread-cutting screws used only if supplied together with the piece in which they are intended to be inserted		N/A
	Thread-cutting screws intended to be used during installation: captive		P
	Screws or nuts which transmit contact pressure made of metal and in engagement with a metal thread		P
	Threaded part torque test	See appended table 26.1	P
26.2	Screws in engagement with a thread of insulating material: correct introduction into the screw hole or nut ensured		N/A
26.3	Contact pressure: not transmitted through insulating material other than ceramic, pure mica or other material no less suitable unless there is sufficient resiliency in metallic parts		P
	Connections made by insulation piercing of tinsel cord reliable		N/A

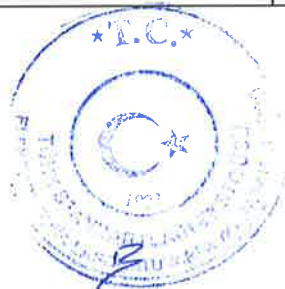

IEC 60884-1			
Clause	Requirement + Test	Result - Remark	Verdict
26.4	Screws and rivets locked against loosening and/or turning		P
26.5	Current-carrying parts (including earthing terminals) have mechanical strength, electrical conductivity and resistance to corrosion adequate:		
	- copper;		N/A
	- alloy with at least 58 % copper for parts made from cold-rolled sheet or with at least 50 % copper for other parts;		P
	- stainless steel with at least 13 % chromium and not more than 0,09 % carbon		N/A
	- steel with electroplated coating of zinc (ISO 2081): service condition ISO no. (1/2/3); IP (X0/X4/X5); thickness (µm) .....		N/A
	- steel with electroplated coating of nickel and chromium (ISO 1456): service condition ISO no. (2/3/4); IP (X0/X4/X5); thickness (µm) .....		N/A
	- steel with electroplated coating of tin (ISO 2093): service condition ISO no. (2/3/4); IP (X0/X4/X5); thickness (µm) .....		N/A
	Current-carrying parts subjected to mechanical wear: not of steel with electroplated coating		N/A
	Metals having a great difference of electrochemical potential: not used in contact with each other		N/A
26.6	Contacts subjected to a sliding action are of metal resistant to corrosion		P
26.7	Thread-forming screws and thread-cutting screws are not used for the connection of current-carrying parts		P
	Thread-forming screws and thread-cutting screws used to provide earthing connection: it is not necessary to disturb the connection and at least two screws are used for each connection		N/A
<b>27</b>	<b>CREEPAGE DISTANCES, CLEARANCES AND DISTANCES THROUGH SEALING COMPOUND</b>		
27.1	Creepage distances, clearances and distances through sealing compound are not less than the values shown in table 23	See appended table 27.1	P
27.2	Insulating sealing compound does not protrude above the edge of the cavity in which it is contained		N/A
27.3	Surface-type socket-outlets do not have bare current-carrying strips at the back		P





IEC 60884-1			
Clause	Requirement + Test	Result - Remark	Verdict
<b>28</b>	<b>RESISTANCE OF INSULATING MATERIAL TO ABNORMAL HEAT, TO FIRE AND TO TRACKING</b>		
<b>28.1</b>	<b>Resistance to abnormal heat and to fire</b>		P
<b>28.1.1</b>	<b>Glow-wire test according to IEC 60695-2-10 and IEC 60695-2-11</b>	See appended table 28.1.1	P
<b>28.1.2</b>	Plugs with pins provided with insulating sleeves:		
	Test temperature maintained for 3 h by means of the apparatus shown in figure 40 at $(120 \pm 5) ^\circ\text{C}$ / $(180 \pm 5) ^\circ\text{C}$ .....		—
	Impact test according to sub-clause 30.4 (mass 100 g, height 100 mm, 4 impacts): no cracks of the insulating sleeves		N/A
<b>28.2</b>	<b>Resistance to tracking</b>		P
	Parts of insulating material retaining live parts in position of accessories having $\text{IP}>\text{X0}$ : of material resistant to tracking		P
	Tracking test at 175 V with solution A of IEC 60112	See appended table 28.2	P
<b>29</b>	<b>RESISTANCE TO RUSTING</b>		
	Ferrous parts protected against rusting		N/A
	Test made after having removed all grease using a suitable degreasing agent: 10 min 10 % solution of ammonium chloride, 10 min in a box with air saturated with moisture and 10 min at $(100 \pm 5) ^\circ\text{C}$ :		N/A
	No signs of rust		N/A
<b>30</b>	<b>ADDITIONAL TESTS ON PINS PROVIDED WITH INSULATING SLEEVES</b>		
<b>30.1</b>	<b>Pressure test at high temperature</b>		N/A
	Apparatus shown in figure 41, with the test specimen in position, maintained for 2 h at $(200 \pm 5) ^\circ\text{C}$ . Force applied through the blade: 2,5 N		N/A
	Thickness of the insulation measured: before the test (mm); after the test (mm) .....		—
	Thickness remaining at the point of impression is not reduced by more than 50 % of its original value measured at the start of the test: percentage value (%) .....		N/A
<b>30.2</b>	<b>Static damp heat test</b>		N/A
	Set of 3 specimens submitted to two damp heat cycles in accordance with IEC 60068-2-30 (variant 2 with a temperature of $40 ^\circ\text{C}$ ).		N/A
	After the test:		N/A
	- insulation resistance and electric strength test (clause 17)		N/A
	- abrasion test (sub-clause 24.7)		N/A
<b>30.3</b>	<b>Test at low temperature</b>		N/A
	Set of 3 specimens maintained at $(-15 ^\circ\text{C} \pm 2) ^\circ\text{C}$ for 24 h		N/A



IEC 60884-1			
Clause	Requirement + Test	Result - Remark	Verdict
	After the test:		N/A
	- insulation resistance and electric strength test (clause 17)		N/A
	- abrasion test (sub-clause 24.7)		N/A
<b>30.4</b>	<b>Impact test at low temperature</b>		N/A
	Specimens maintained at $(-15\text{ °C} \pm 2)\text{ °C}$ for 24 h subjected to 4 impacts (mass 100 g, height 100 mm) by means of the apparatus shown in figure 42 rotating the specimen through $90\text{ °}$ between impacts		N/A
	After the test: no crack of the insulating sleeves		N/A

TRF No. IEC60884\_1G



IEC 60884-1			
Clause	Requirement + Test	Result - Remark	Verdict

12.2.5 TABLE: test with apparatus shown in figure 11 (screw-type terminals)				
	rated current (A) .....	16A		—
	type of conductors .....	rigid solid / rigid stranded / flexible		—
	smallest/largest cross-sectional area per table 3 (mm <sup>2</sup> ) .....	1,5 mm <sup>2</sup> /2x2,5 mm <sup>2</sup>		—
	number of conductors .....	1/2		—
	nominal diameter of thread (mm); torque per table 6 (Nm) .....	3,34 mm ; 0,8 Nm		—
Cross-sectional area (mm <sup>2</sup> )	Diameter of bushing hole per table 9 (mm)	Height H per table 9 (mm)	Mass (kg)	Remarks
1,5 mm <sup>2</sup>	6,5 mm	260 mm	0,4 kg	P
2x2,5 mm <sup>2</sup>	9,5 mm	280 mm	0,7 kg	P
supplementary information:				

12.2.6 TABLE: pull test (screw-type terminals)				
	rated current (A) .....	16 A		—
	smallest/largest cross-sectional area per table 3 (mm <sup>2</sup> ) .....	1,5 mm <sup>2</sup> /2x2,5 mm <sup>2</sup>		—
	nominal diameter of thread (mm); torque 2/3 per table 6 (Nm) .....	3,34 mm / 0,54Nm		—
Cross-sectional area (mm <sup>2</sup> )	Number of conductors	Type of conductors (rigid solid / rigid stranded / flexible)	Pull per table 4 applied for 1 min (N)	Remarks
1,5 mm <sup>2</sup>	1/2	rigid solid / rigid stranded	40 N	P
2x2,5 mm <sup>2</sup>	1/2	rigid solid / rigid stranded	50 N	P
supplementary information:				



IEC 60884-1			
Clause	Requirement + Test	Result - Remark	Verdict

12.2.7		TABLE: tightening test (screw-type terminals)		
	rated current (A) .....	16 A		—
	nominal diameter of thread (mm); torque 2/3 per table 6 (Nm) .....	3,34 mm / 0,54Nm		—
Largest cross-sectional area per table 3 (mm <sup>2</sup> )	Permissible number of conductors <sup>(1)</sup>	Type of conductors (rigid solid / rigid stranded / flexible)	Number of wires and nominal diameter of wires per table 5	Remarks
2,5 mm <sup>2</sup>	1/2	rigid solid	1x1,78 mm	P
2,5 mm <sup>2</sup>	1/2	rigid stranded	7x0,67 mm	P
supplementary information:				
<sup>(1)</sup> terminals intended for looping-in 2 or 3 conductors				

12.3.10		TABLE: mechanical strength test (screwless-type terminals)			
	rated current (A) .....				—
	largest/smallest cross-sectional area per table 7 (mm <sup>2</sup> ) .....				—
Number of connection (after that conductor subjected to a pull of 30 N for 1 min) / disconnection	Type of conductor (solid / rigid stranded / flexible)	Cross-sectional area (mm <sup>2</sup> )	Remarks		
TABLE: test with apparatus shown in figure 11					
Cross-sectional area (mm <sup>2</sup> )	Type of conductor (solid / rigid stranded / flexible)	Diameter of bushing hole per table 9 (mm)	Height H per table 9 (mm)	Mass (kg)	Remarks
supplementary information:					



IEC 60884-1			
Clause	Requirement + Test	Result - Remark	Verdict

<b>12.3.11</b>	<b>TABLE: electrical and thermal strength test (screwless-type terminals)</b>						
<b>Test a)</b>	<b>Test carried out for 1 h connecting rigid solid conductors:</b>						
	<b>test current per table 10 (A) .....</b>					—	
	<b>nominal cross-sectional area (mm<sup>2</sup>) .....</b>					—	
	<b>Screwless terminal number</b>	<b>Voltage drop (mV)</b>			<b>Required voltage drop (mV)</b>		
	1				≤ 15		
	2				≤ 15		
	3				≤ 15		
	4				≤ 15		
	5				≤ 15		
<b>Test b)</b>	<b>Temperature cycles test carried out on terminals subjected to Test a):</b>						
	<b>test current per table 10 (A) .....</b>					—	
	<b>nominal cross-sectional area (mm<sup>2</sup>) .....</b>					—	
	<b>allowed voltage drop (mV) .....</b>	≤ 22,5 mV or 2 times 24 <sup>th</sup> cycle value (mV)				—	
	<b>Screwless terminal number</b>	<b>1</b>	<b>2</b>	<b>3</b>	<b>4</b>	<b>5</b>	<b>Remarks</b>
	<b>voltage drop after 24<sup>th</sup> cycle</b>						
	<b>voltage drop after 48<sup>th</sup> cycle</b>						
	<b>voltage drop after 72<sup>nd</sup> cycle</b>						
	<b>voltage drop after 96<sup>th</sup> cycle</b>						
	<b>voltage drop after 120<sup>th</sup> cycle</b>						
	<b>voltage drop after 144<sup>th</sup> cycle</b>						
	<b>voltage drop after 168<sup>th</sup> cycle</b>						
	<b>voltage drop after 192<sup>nd</sup> cycle</b>						
<b>12.3.10</b>	<b>TABLE: mechanical strength test (screwless-type terminals)</b>						
	<b>rated current (A) .....</b>					—	
	<b>largest/smallest cross-sectional area per table 7 (mm<sup>2</sup>) .....</b>					—	
	<b>Number of connection (after that conductor subjected to a pull of 30 N for 1 min) / disconnection</b>	<b>Type of conductor (solid / rigid stranded / flexible)</b>			<b>Cross-sectional area (mm<sup>2</sup>)</b>	<b>Remarks</b>	
	<b>TABLE: test with apparatus shown in figure 11</b>						

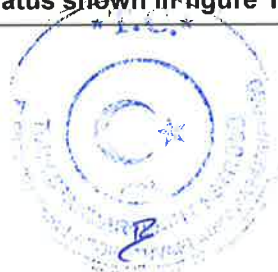



IEC 60884-1					
Clause	Requirement + Test	Result - Remark		Verdict	
Cross-sectional area (mm <sup>2</sup> )	Type of conductor (solid / rigid stranded / flexible)	Diameter of bushing hole per table 9 (mm)	Height H per table 9 (mm)	Mass (kg)	Remarks
<b>supplementary information:</b>					

<b>12.3.12</b>	<b>TABLE: deflection test (principle of test apparatus shown in figure 12a)</b>							
	Test carried out connecting rigid solid copper conductors:							
	test current (A) (equal rated current) .....						—	
	required voltage drop (mV) .....	≤ 25 mV					—	
Type of conductor		Smallest			Largest			Remarks
cross-sectional area per table 11 (mm <sup>2</sup> )								
force per table 12 (N)								
screwless terminal number		1	2	3	1	2	3	
starting point (X = deflection original point)		X	X+10°	X+20°	X	X+10°	X+20°	
voltage drop 1 <sup>st</sup> deflection (mV)								
voltage drop 2 <sup>nd</sup> deflection (mV)								
voltage drop 3 <sup>rd</sup> deflection (mV)								
voltage drop 4 <sup>th</sup> deflection (mV)								
voltage drop 5 <sup>th</sup> deflection (mV)								
voltage drop 6 <sup>th</sup> deflection (mV)								
voltage drop 7 <sup>th</sup> deflection (mV)								
voltage drop 8 <sup>th</sup> deflection (mV)								
voltage drop 9 <sup>th</sup> deflection (mV)								
voltage drop 10 <sup>th</sup> deflection (mV)								
voltage drop 11 <sup>th</sup> deflection (mV)								
voltage drop 12 <sup>th</sup> deflection (mV)								
<b>supplementary information:</b>								



IEC 60884-1			
Clause	Requirement + Test	Result - Remark	Verdict

14.22	TABLE: Components					
Object / part No.	Manufacturer/ trademark	Type / model	Technical data	Standard	Mark(s) of conformity <sup>1)</sup>	
<b>- Description:</b>						
<b>Supplementary information:</b>						
<sup>1)</sup> Provided evidence ensures the agreed level of compliance. See OD-CB2039.						

17.1	TABLE: insulation resistance (154 XXXX 07 117, 154 XXXX 07 120)			
Item per 17.1	test voltage applied between:	measured (M $\Omega$ )	required (M $\Omega$ )	
a)	All poles connected together and body	>1000 M $\Omega$	$\geq$ 5 M $\Omega$	
b)	Between each pole in turn and all other poles connected to the body	>1000 M $\Omega$	$\geq$ 5 M $\Omega$	
supplementary information:				

17.2	TABLE: electric strength (154 XXXX 07 117, 154 XXXX 07 120)			
	rated voltage (V) .....	250 V		—
item per 17.1	test voltage applied between:	test voltage (V)	flashover / breakdown (Yes/No)	
a)	All poles connected together and body	2000 V	No	
b)	Between each pole in turn and all other poles connected to the body	2000 V	No	
supplementary information:				

19.1	TABLE: temperature rise test for socket-outlets and plugs			
	rated current of accessory (A) .....	16A		—
	type of accessory (non-rewirable / rewirable) ....	rewirable		—
	nominal cross-sectional area per table 15 (mm <sup>2</sup> ) :	2,5 mm <sup>2</sup>		—
	type of conductors (rigid solid / rigid stranded / flexible) .....	rigid solid		—
	nominal diameter of thread (mm); torque 2/3 of that specified in 12.2.8 (Nm.....)	3,34 mm / 0,54Nm		—



IEC 60884-1							
Clause	Requirement + Test			Result - Remark			Verdict
specimen	type of flexible cable <sup>(1)</sup>	number of conductors and nominal cross-sectional area (mm <sup>2</sup> ) <sup>(1)</sup>	test circuit (L-L/L-N/L-E)	test current (table 20) for 1 h (A)	measured ΔT (K)	allowed ΔT (K)	ΔT of external parts of insulating material (25.3)(K)
No.1	--	--	L-N/L-E	16A	37,6 / 28,4	45K	2,5 / 2,7
No.2	--	--	L-N/L-E	16A	35,8 / 30,2	45K	2,9 / 2,9
No.3	--	--	L-N/L-E	16A	34,9 / 28,3	45K	3,3 / 3,0
<b>supplementary information:</b>							
<b>(1) Non-rewirable accessories</b>							

<b>19.2</b>	<b>TABLE: temperature rise test for fixed socket-outlets of a socket-outlet and fused plug system</b>									
	<b>rated current of accessory (A) .....</b>									—
	<b>type of accessory (non-rewirable / rewirable) ....</b>									—
	<b>nominal cross-sectional area per table 15 (mm<sup>2</sup>) :</b>									—
	<b>type of conductors (rigid solid / rigid stranded / flexible).....</b>									—
	<b>nominal diameter of thread (mm); torque 2/3 of that specified in 12.2.8 (Nm.....</b>									—
<b>Test a) single socket-outlet</b>										
specimen	type of flexible cable <sup>(1)</sup>	number of conductors and nominal cross-sectional area (mm <sup>2</sup> ) <sup>(1)</sup>	test circuit (L-L/L-N/L-E)	70% of test current (table 20) for 1 h (socket-outlet) (A)	30% of test current (table 20) for 1 h (looped) (A)	test current (table 20) for 1 h (supply cable) (A)	measured ΔT (K)	allowed ΔT (K)	ΔT of external parts of insulating material (25.3)(K)	
supplementary information: <sup>(1)</sup> Non-rewirable accessories										
<b>Test b) multiple socket-outlet</b>										
specimen	type of flexible cable <sup>(1)</sup>	number of conductors and nominal cross-sectional area (mm <sup>2</sup> ) <sup>(1)</sup>	test circuit (L-L/L-N/L-E)	70% of test current (table 20) for 1 h (1 <sup>st</sup> socket-outlet) (A)	30% of test current (table 20) for 1 h (2 <sup>nd</sup> socket) (A)	test current (table 20) for 1 h (supply cable) (A)	measured ΔT (K)	allowed ΔT (K)	ΔT of external parts of insulating material (25.3)(K)	



IEC 60884-1									
Clause	Requirement + Test	Result - Remark	Verdict						
supplementary information: <sup>(1)</sup> Non-rewirable accessories									

19.3	TABLE: temperature rise test for plugs and portable socket-outlets with incorporated components								
	rated current of accessory (A) .....								—
	type of accessory (non-rewirable / rewirable) .....								—
	nominal cross-sectional area per table 15 (mm <sup>2</sup> ) .....								—
	type of conductors (rigid solid / rigid stranded / flexible).....								—
	nominal diameter of thread (mm); torque 2/3 of that specified in 12.2.8 (Nm .....								—
Test for Portable socket-outlets and rewirable plugs with incorporated components									
specimen	type of flexible cable <sup>(1)</sup>	number of conductors and nominal cross-sectional area (mm <sup>2</sup> ) <sup>(1)</sup>	test circuit (L-L/L-N/L-E)	Test current (table 20), Clause 19 for 1 h (components short circuited) (A)	Test current is rated current of the portable accessory or the rated current of the component (s), whichever is the lower (A)	measured ΔT (K)	allowed ΔT (K)	ΔT of external parts (25.3)(K) <sup>(2)</sup>	
supplementary information: <sup>(1)</sup> Non-rewirable accessories ; <sup>(2)</sup> Metal parts 30 K ; non-metallic parts 40 K									
Test for non-rewirable plugs with incorporated components									
specimen	type of flexible cable (1)	number of conductors and nominal cross-sectional area (mm <sup>2</sup> ) (1)	test circuit (L-L/L-N/L-E)	Test current is equal to the test current for the combination of the plug and the cable as indicated in Table 20, for Clause 19. (components short circuited) (A)	Test current is equal to the test current for the combination of the plug and the cable as indicated in Table 20, for Clause 21 or the rated current of the component (s), whichever is the lower (A)	measured ΔT (K)	allowed ΔT (K)	ΔT of external parts (25.3)(K) <sup>(2)</sup>	
supplementary information: <sup>(1)</sup> Non-rewirable accessories; <sup>(2)</sup> Metal parts 30 K ; non-metallic parts 40 K									





IEC 60884-1									
Clause	Requirement + Test			Result - Remark				Verdict	
<b>20</b>	<b>TABLE: breaking capacity</b>								
	rating of accessory (A/V) .....			16A/250V				—	
	type of accessory (non-rewirable / rewirable) .....			rewirable				—	
	type of flexible cable (non-rewirable accessories) .....			--				—	
	number of conductors and nominal cross-sectional area (mm <sup>2</sup> ) (non-rewirable accessories) .....			--				—	
	nominal cross-sectional area per table 15 (mm <sup>2</sup> ) :			2,5 mm <sup>2</sup>				—	
	type of conductors (rigid solid / rigid stranded / flexible) .....			rigid solid				—	
	nominal diameter of thread (mm); torque 2/3 of that specified in 12.2.8 (Nm) .....			3,34 mm / 0,54Nm				—	
	rate of operation (strokes per minute) .....			30 strokes				—	
specimen	test plug (for each type and current rating of socket-outlet)		test voltage (1,1 Vn) (V)	test current (1,25 In) cos φ 0,6 (A)	number of strokes (plugs only)	number of strokes, with shutters – with current <sup>(1)</sup>	number of strokes, without shutters – with current <sup>(2)</sup>	remarks	
	pin dimensions (mm)	pin spacing (mm)							
No.1	Ø4,8±0,06	19±0,2	275	20A	--	--	100	--	<b>P</b>
No.2	Ø4,8±0,06	19±0,2	275	20A	--	--	100	--	<b>P</b>
No.3	Ø4,8±0,06	19±0,2	275	20A	--	--	100	--	<b>P</b>
supplementary information: <sup>(1)</sup> starting point 1 or 3 of Figure 43 <sup>(2)</sup> starting point 2 of Figure 43									

<b>21</b>	<b>TABLE: normal operation</b>								
	rating of accessory (A/V) .....			16A/250V				—	
	type of accessory (non-rewirable / rewirable) .....			rewirable				—	
	type of flexible cable (non-rewirable accessories) .....			--				—	
	number of conductors and nominal cross-sectional area (mm <sup>2</sup> ) (non-rewirable accessories) .....			--				—	
	nominal cross-sectional area per table 15 (mm <sup>2</sup> ) :			2,5 mm <sup>2</sup>				—	
	type of conductors (rigid solid / rigid stranded / flexible) .....			rigid solid				—	
	nominal diameter of thread (mm); torque 2/3 of that specified in 12.2.8 (Nm) .....			3,34 mm / 0,54Nm				—	
	rate of operation (strokes per minute) .....			30 strokes				—	

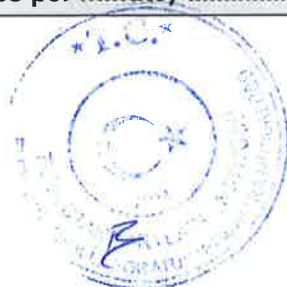



IEC 60884-1									
Clause	Requirement + Test					Result - Remark			Verdict
specimen	test plug (for each type and current rating of socket-outlet)		test voltage (Vn) (V)	test current (table 20), $\cos \varphi 0,8$ (A)	number of strokes (plugs only)	number of strokes, with shutters – with current <sup>(1)</sup>	number of strokes, without shutters – with current <sup>(2)</sup>	number of strokes, with shutters – without current <sup>(3)</sup>	
	pin dimensions (mm)	pin spacing (mm)							
No.1	$\varnothing 4.8 \pm 0.06$	$19 \pm 0,2$	250	16A	--	--	10000	--	P
No.2	$\varnothing 4.8 \pm 0.06$	$19 \pm 0,2$	250	16A	--	--	10000	--	P
No.3	$\varnothing 4.8 \pm 0.06$	$19 \pm 0,2$	250	16A	--	--	10000	--	P
<b>TABLE: test for shuttered socket-outlets</b>									
specimen	Gauge of figure 9, applied with a force of 20 N, for approximately 5 s, successively in three directions				Steel gauge of figure 10, applied with a force of 1 N for approximately 5 s, in three directions				
<b>19</b>	<b>TABLE: temperature rise test</b>								
specimen	test circuit (L-L/L-N/L-E)	test current (table 20 for clause 21) for 1 h (A)		measured dT (K)	allowed dT (K)				
No.1	N-L / L-E	16A		32,1 / 25,2	45K		P		
No.2	N-L / L-E	16A		32,7 / 24,0	45K		P		
No.3	N-L / L-E	16A		33,6 / 25,0	45K		P		
<b>17.2</b>	<b>TABLE: electric strength</b>								
specimen	item per 17.1	test voltage applied between:			test voltage (V)	flashover / breakdown (Yes/No)			
No.1	a) ,b)				1500 V	No			
No.2	a) ,b)				1500 V	No			
No.3	a) ,b)				1500 V	No			
<b>supplementary information:</b> <sup>(1)</sup> starting point 1 or 3 of Figure 43 <sup>(2)</sup> starting point 2 of Figure 43 <sup>(3)</sup> starting point 1 or 2 of Figure 43									

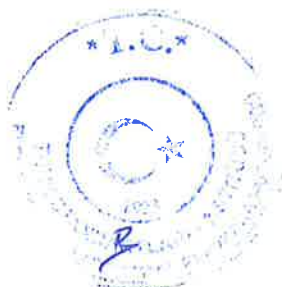

IEC 60884-1					
Clause	Requirement + Test			Result - Remark	Verdict
<b>22</b>	<b>TABLE: force necessary to withdraw the plug</b>				
	Rated current (A) .....			16A	—
	Number of poles .....			3	—
<b>22.1</b>	<b>Verification of the maximum withdrawal force</b>				
<b>specimen</b>	<b>socket-outlets (multi-pin gauge)</b>		<b>plugs with resilient earthing contact assemblies (single-pin gauge)</b>		
	<b>maximum withdrawal force (N)</b>	<b>the test plug did not remain in the socket-outlet (Y/N)</b>	<b>maximum withdrawal force (N)</b>	<b>the test pin gauge did not remain in the contact assembly</b>	
No.1	54 N	Y	--	--	P
No.2	54 N	Y	--	--	P
No.3	54 N	Y	--	--	P
<b>22.2</b>	<b>Verification of the minimum withdrawal force</b>				
<b>specimen</b>	<b>socket-outlets (single-pin gauge)</b>		<b>plugs with resilient earthing contact assemblies (single-pin gauge)</b>		
	<b>minimum withdrawal force (N)</b>	<b>the test pin gauge did not fall from each individual contact-assembly within 30 s (Y/N)</b>	<b>minimum withdrawal force (N)</b>	<b>the test pin gauge did not fall from each individual earthing contact-assembly within 30 s (Y/N)</b>	
No.1	2 N	Y	--	--	P
No.2	2 N	Y	--	--	P
No.3	2 N	Y	--	--	P
<b>supplementary information:</b>					

<b>23.2</b>	<b>TABLE: pull and torque test</b>				
	rating of accessory (A) .....				—
	type of accessory (non-rewirable / rewirable) .....				—
	smallest/largest cross-sectional area per table 17 (mm <sup>2</sup> ) (rewirable accessories) .....				—
	nominal diameter of thread (mm); torque 2/3 per table 6 (Nm) (rewirable accessories) .....				—
<b>specimen</b>	<b>type of flexible cable</b>	<b>number of conductors and nominal cross-sectional area (mm<sup>2</sup>)</b>	<b>pull (100 times) (N)</b>	<b>torque (1 min) as specified in table 18 (Nm)</b>	<b>displacement (mm)</b>



IEC 60884-1					
Clause	Requirement + Test			Result - Remark	Verdict
<b>supplementary information:</b>					

23.1	TABLE: flexing test				
	rated current (A) .....				—
specimen	type of flexible cable	number of conductors and nominal cross-sectional area (mm <sup>2</sup> )	test current (A)	mass (N)	
<b>supplementary information:</b>					

24.1	TABLE: impact test			
part of enclosure tested per table 21 (A, B, C, D)	blows per part	height of fall (mm)	comments	
A	5	120 mm	P	
D	4	200 mm	P	
<b>supplementary information:</b>				

25.2	TABLE: ball pressure test of insulating materials			
	allowed impression diameter (mm) .....		≤ 2 mm	—
part under test	test temperature (°C)	impression diameter (mm)		
Parts of insulating material necessary to retain current-carrying parts and parts of the earthing circuit in position	125±2	1,277		
Parts of the front surface zone of thermoplastic material, 2 mm wide, surrounding the phase and neutral pin entry holes of socket-outlets	125±2	1,154		
<b>supplementary information:</b>				



IEC 60884-1			
Clause	Requirement + Test	Result - Remark	Verdict
25.3	<b>TABLE: ball pressure test of insulating materials</b>		
	<b>allowed impression diameter (mm) .....</b>	<b>≤ 2 mm</b>	—
part under test		test temperature (°C) <sup>(1)</sup>	impression diameter (mm)
Base (upper body)		70 ± 2	< 1,50
Base (lower body)		70 ± 2	< 1,50
Increased protection cover		70 ± 2	< 1,50
Internal body carcass		70 ± 2	< 1,50
Main body – Upper body spacer part		70 ± 2	< 1,50
<b>supplementary information:</b>			
<sup>(1)</sup> (70 ± 2) °C / (40 ± 2) °C + highest temperature rise determined during the test of clause 19			

26.1 TABLE: threaded part torque test					
threaded part identification	diameter of thread (mm)	column number (1, 2 or 3)	applied torque (Nm)	times (5/10)	no damage
Terminal screws	3,34	2	0,8	5	P
Internal mounting screws	3,06	2	0,6	10	P
Base screws	3,89	2	1,2	10	P
<b>supplementary information:</b>					

27.1 TABLE: creepage distances, clearances and distances through sealing compound (154 XXXX 07 117, 154 XXXX 07 120)								
rated voltage (V) .....		250 V						—
item per table 23	creepage distance dcr, clearance cl and distance through sealing compound dtsc at/of:	require d cl (mm)	cl (mm)	require d dcr (mm)	dcr (mm)	require d dtsc (mm)	dtsc (mm)	
1		≥--	--	≥3	>3	≥--	--	
2		≥--	--	≥3	>3	≥--	--	
6		≥3	>3	≥--	--	≥--	--	
7		≥3	>3	≥--	--	≥--	--	
<b>supplementary information:</b>								



IEC 60884-1					
Clause	Requirement + Test	Result - Remark			Verdict
<b>28.1.1</b>	<b>TABLE: glow-wire test</b>				
part under test	material designation	test temperature (°C)	visible flame and sustained glowing (Y/N)	flame and glowing extinction time	ignition of the tissue paper (Y/N)
Parts of insulating material necessary to retain current-carrying parts and parts of the earthing circuit in position		850	N	--	N
Upper body		650	N	--	N
Base (upper body)		650	N	--	N
Base (lower body)		650	N	--	N
Increased protection cover		650	N	--	N
Internal body carcass		650	N	--	N
Main body – Upper body spacer part		650	N	--	N
Cable entry parts		650	N	--	N
<b>supplementary information:</b>					

<b>28.2</b>	<b>TABLE: resistance to tracking</b>			
	number of drops .....	50		—
part under test	material designation	test voltage (V)	flashover / breakdown (Yes/No)	
Parts of insulating material retaining live parts in position		175	No	
<b>supplementary information:</b>				





**TABLE 2**  
(TS 40 / Sheet 7 = CEE 7: Sheet III )

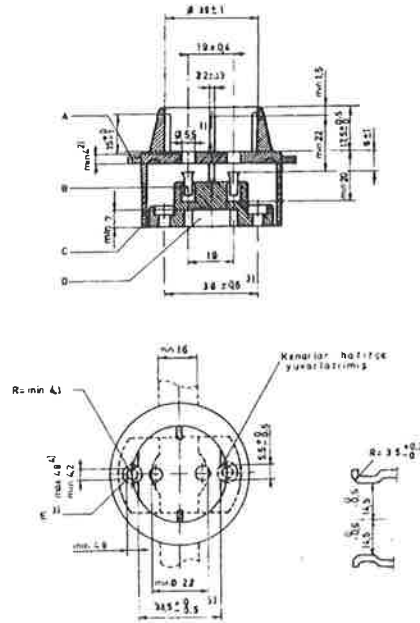

Dimensions	154 XXXX 07 117	154 XXXX 07 120
$19 \pm 0,4$	18,87	18,89
$\phi 5,5$	5,71	5,73
$17,5 + 0,5 ; - 0$	17,95	17,93
$15 + 0 ; - 1$	14,26	14,30
$39 \pm 1$	38,84	38,80
$8 \pm 1$	7,93	7,96
Min 22	22,62	22,68
Min 1,5	3,09	3,05
$2,2 \pm 0,3$	2,32	2,30
Min 20	20,90	20,93
Min 4	>4,00	>4,00
$33,5 + 0 ; - 0,5$	33,26	33,28
$5,5 + 0 ; - 0,5$	5,19	5,21
$14,5 + 0 , - 0,5$	14,47	14,46
$R=3,5+0,3$	3,50	3,50



## Kullanılan deney cihaz listesi ( Device List ) ( TS IEC 60884-1 / TS 40 / TS IEC 60884-2-5)

	Madde ( Clause )	Ölçme ve Deney Adı ( Measurement and Test Name )	Kullanılan Deney, Ölçüm Cihazları ve seri no ( Measurement - Test Device and Serial number )	Kullanılan Aralık ( Usage range )
<input checked="" type="checkbox"/>	9	Boyutların kontrolü <i>Dimensional measurement</i>	Dijital Kumpas ve Mastarlar S.N.:03005495 S.N:16400103015	0 – 150 mm
<input checked="" type="checkbox"/>	10	Elektrik Çarpmasına Karşı Koruma <i>Protection against electric shock</i>	Deney Parmakları ve Şekil 13'de ki Deney Pini, Etüv Mastar 37020Z26, 37020Z27, 37020Z41, 37020Z35	1N – 100N, 0 °C – 250 °C
<input checked="" type="checkbox"/>	11	Topraklama düzeni <i>Provision for earthing</i>	Kikusui T056210 S.N:TE002268	0-250 mΩ 0-60 A
<input checked="" type="checkbox"/>	12.2	Bağlantı uçları <i>Terminals</i>	CEDAR DID-4 S.N:71161 Tohnichi RTD 60CN S.N:438176E Tohnichi RTD 260CN S.N:400681F	0 - 4 Nm
<input type="checkbox"/>	12.3	Vidasız Bağlantı uçları <i>Conductor deflecting test</i>	Cihaz 1: APS081204 Cihaz 2: APS081205	-
<input checked="" type="checkbox"/>	13,14	Yapılış kuralları <i>Constructional requirements</i>	Etüv FN 500 S.N.: 301160119775	0 °C – 250 °C
<input checked="" type="checkbox"/>	16	Yaşlanmaya,zararlı su girişine ve neme karşı dayanıklılık <i>Resistance to ageing, to harmful ingress of water and to humidity</i>	Etüv FN 500 S.N.: 301160119775 İklimlendirme kabini Angelantoni UC9-10+60 S.N:37020 K030 İklimlendirme kabini ACS/CH340E S.N: 104106 WEISS TECHNIK ST 1800-U FRIBORG 6100	0 °C – 250 °C -10°C / +60°C 30% / 95% Rh 0°C / +40°C 50% / 95% Rh Max load 50 Kg 20 mbar 0-10 bar 100 lt 1/6.3 mm-2/12.5 mm
<input checked="" type="checkbox"/>	17	Yalıtım direnci ve elektriksel dayanım <i>Insulation resistance and electric strength</i>	MEGGER MIT520 071007/1497 HIOKI 3153	100-500-1000V 10Kohm – 1Tohm 0 – 5500 V
<input checked="" type="checkbox"/>	19	Sıcaklık artışı deneyi <i>Temperature-rise test</i>	MATEŞ 081104 MULTITECH 22581 CIE 305 CIE 306 37020 H13 37020 H14	0 – 80A 0 – 50A + Termometre -50 °C / 1300 °C
<input checked="" type="checkbox"/>	20	Kesme kapasitesi <i>Breaking capacity tests specified according of he ratings</i>	EMS ULS-2008 2008-01 APS 081130 APS 081128	0-30 A, 200V – 275V 0.30 – 0.95 cosφ 0 °C – 250 °C
<input checked="" type="checkbox"/>	21	Normal çalışma <i>Normal operation, tests specified according of he ratings</i>	EMS ULS-2008 2008-01 APS 081130 APS 081128	0-30 A, 200V – 275V 0.30 – 0.95 cosφ 0 °C – 250 °C
<input checked="" type="checkbox"/>	22	Fişin çıkartılması için gerekli kuvvet <i>Force necessary to withdraw the plug</i>	Çıkartma Kuvveti Doğrulama Cihazı 253.3.4/11/10572	2N-54 N
<input type="checkbox"/>	23	Bükülgen kablolar ve bağlantıları <i>Flexible cables and their connection</i>	Kordon bağlantısı deney aparatı 253.3.4/11/10684 Bükülgenlik deney aleti 253.3.4/11/10635 Bükme deneyi aparatı 438694K	-- +90°, -90° 1-50 cNm
<input checked="" type="checkbox"/>	24	Mekanik dayanım <i>Mechanical strength</i>	Tumbling barrel Friborg 5100 37020 Y55 Pendulum Impact Hammer Friborg 5950 970013-08 Tohnichi RTD 60CN S.N:438176E Tohnichi RTD 260CN S.N:400681F CEDAR DID-4 S.N:71161	-- 0- 4 Nm
<input checked="" type="checkbox"/>	25	Isıya dayanıklılık <i>Resistance to heat, treatments according to test specifications</i>	Etüv NUVE FN 500 S.N:3011601197775 Etüv Panasonic MOV212F-PE 12050017 Friborg Bilya Basınc Aparatı	0 °C – 250 °C Diameter : 5 mm / 20 N
<input checked="" type="checkbox"/>	26	Vidalar akım taşıyan bölümler ve bağlantılar <i>Screws, current carrying parts and connections</i>	Tohnichi RTD 60CN S.N:438176E Tohnichi RTD 260CN S.N:400681F CEDAR DID-4 S.N:71161	0- 4 Nm
<input checked="" type="checkbox"/>	27	Yüzeysel kaçak yolu uzunlukları ve yalıtma aralıkları <i>Creepage distances, clearances</i>	Friborg 37020 Z29	1 – 1.5 – 2 – 2.5 – 3 – 3.5 – 4 – 4.5 – 5 – 5.5 – 6 – 6.5 – 7 – 7.5 – 8 – 8.5 – 9 – 9.5 – 10 mm
<input checked="" type="checkbox"/>	28	Yalıtkan malzemenin olağan dışı ısıya,yanmaya ve yüzeysel kaçaklara dayanıklılığı <i>Resistance of insulating material to abnormal heat, to fire and to tracking</i>	EMS GW – 2013 FRIBORG / 4200 S.N: 970013-02	0 – 1000 °C K Type Thermocouple 0 - 1000V tracking test
<input type="checkbox"/>	29	Paslanmaya karşı dayanıklılık <i>Resistance to rusting, treatment</i>	Etüv NUVE FN 500 S.N:3011601197775 İklimlendirme kabini Angelantoni UC9-10+60 S.N:37020 K030	0 °C – 250 °C 30% / 95% Rh 300 °C



